

# Spray Nozzle Products for Automotive Manufacturing

“The Fog Engineers”  
いけうち **H. IKEUCHI & Co., LTD.**

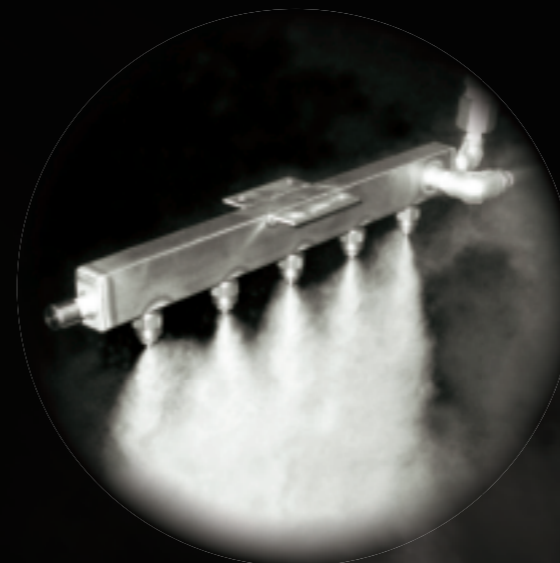

## Headquarters

Daiichi Kyogyo Bldg., 1-15-15, Awaza  
Nishi-ku, Osaka 550-0011, Japan  
Tel: 81-6-6538-4015 Fax: 81-6-6538-4022  
e-mail: [overseas@kirinoikeuchi.co.jp](mailto:overseas@kirinoikeuchi.co.jp)  
URL: <http://www.kirinoikeuchi.co.jp/eng/>

## Overseas network

### IKEUCHI USA, INC.

8110 Beckett Center Drive, West Chester OH 45069, USA  
Tel: 1-513-942-3060 Fax: 1-513-942-3064  
[info@ikeuchiusa.com](mailto:info@ikeuchiusa.com)  
<http://www.ikeuchiusa.com/>

### IKEUCHI (SHANGHAI) CO., LTD.

Room C, 21/F, Electrical & Mechanical Bldg.,  
600 Hengfeng Road, Shanghai 200070, P.R.China  
Tel: 86-21-6140-9731 Fax: 86-21-6123-4239  
[mist@kirinoikeuchi.com](mailto:mist@kirinoikeuchi.com) (for Shanghai, Tianjin, Shenzhen offices)  
<http://www.kirinoikeuchi.com/>

**Tianjin Branch** Tel: 86-22-2320-1676 Fax: 86-22-2320-1675  
**Shenzhen Branch** Tel: 86-755-8525-2221 Fax: 86-755-8525-2215

### PT.IKEUCHI INDONESIA

Ruko Easton Jalan Gunung Panderman Blok E No.9,  
Lippo Cikarang Kel.Cibatu Kec., Cikarang Selatan Bekasi 17550  
Indonesia  
Tel: 62-21-2909-3246 Fax: 62-21-2909-3247  
[sales@ikeuchi.co.id](mailto:sales@ikeuchi.co.id)  
<http://www.kirinoikeuchi.co.jp/ijk/>

### IKEUCHI EUROPE B.V.

Asterweg 17 A6, 1031 HL Amsterdam, The Netherlands  
Tel: 31-20-820-2175 Fax: 31-20-820-2176  
[info@ikeuchieurope.com](mailto:info@ikeuchieurope.com)  
<http://www.ikeuchieurope.com/>

### IKEUCHI TAIWAN CO., LTD.

11F-1, No.27, Sec. 1, Chung Shan N. Rd., Taipei Taiwan, R.O.C.  
Tel: 886-2-2511-6289 Fax: 886-2-2541-6392  
[sales@ikeuchi.com.tw](mailto:sales@ikeuchi.com.tw)  
<http://www.ikeuchi.com.tw/>



# Proven technology creating a new era for the automotive industry

Cleaning, cooling, dust suppression, humidification, air blowers, and more for production facilities with increasingly diverse and complex needs...

Our products meet the growing demands for saving energy, water and electricity, recycling, and protection of the environment.

As one of the main industries supporting the economy, automotive manufacturing has a large number of high-tech needs.

H. IKEUCHI & CO., LTD. has decades of experience in research and development of industrial spray nozzles and nozzle-related systems.

With our Fog Engineers' record of performance, technology, and know-how, you can count on our support to meet your diversifying needs.

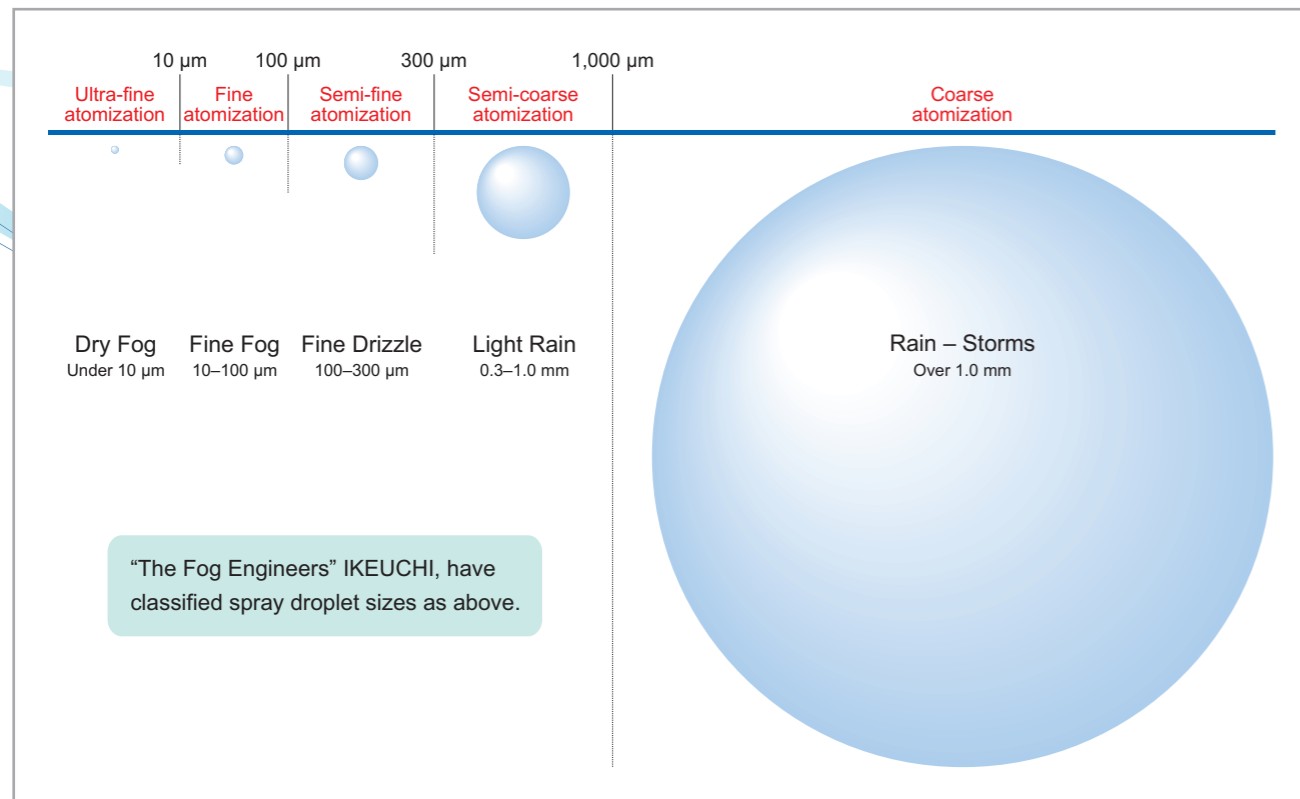

## Guarantee of Precision Nozzle Performance

All IKEUCHI's precision-made hydraulic spray nozzles are guaranteed for spray angles and spray capacities. This guarantee covers metal, plastic, and ceramic nozzles. IKEUCHI sets a strict acceptance criteria for spray performance and only the nozzles that pass the inspection will be shipped.

### Spray Capacity Tolerance

Guaranteed to within +/- 5% of the rated spray capacity under the standard pressure.

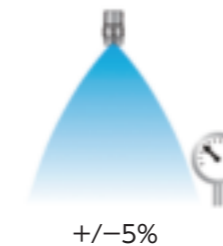

### Spray Angle Tolerance

Guaranteed to within +/- 5 degrees of the rated spray angle under the standard pressure. Spray angle is the angle of spray measured near the nozzle, unless otherwise specified.



### Spray Angle Tolerance for Solid Stream Jet

Solid stream jet nozzles are guaranteed for the axis of spray direction within 3 degrees from the nozzle body centerline under the standard pressure.



### Spray Pattern

A standard pressure is defined as the design pressure based on the common liquid pressure during normal use for each hydraulic spray nozzle series. Nozzles are designed to provide the specified spray capacity, spray angle, optimal spray pattern (cross sectional shape of the spray) and spray distribution at each standard pressure. IKEUCHI sets an original inspection standard for the spray pattern, too. Each pneumatic spray nozzle series also has spray capacity inspection standard at each standard pressure. Only the nozzles that pass the inspection will be shipped.

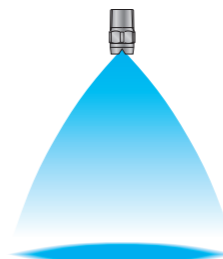

Note:  
1) The figures in this catalog are based on tap water at room temperature and the liquid pressure is measured at the immediate upstream of the nozzle.  
2) The above guarantee does not cover air nozzles. Air consumption (blowing air volume) shown in this catalog is for reference only.  
3) EJX series Ejector nozzles are guaranteed only for spray capacities.

## INDEX

- | Spray Nozzle Uses in Automotive Manufacturing Processes..... p.3
- | How to Use This Catalog..... p.4
- | Cooling Systems/Units..... p.5
- | Humidification Systems/Units..... p.7
- | Spray Nozzle Product Line, Related Products..... p.9
- | BIM series Pneumatic Fine Fog Spray Nozzles..... p.10
- | AKIMist® "E" Dry Fog Humidifiers..... p.15
- | SETO-SD series Solenoid-activated Pneumatic Spray Nozzles..... p.17
- | YYA series Wide-angle Flat Pneumatic Spray Nozzles..... p.18
- | UT+VP/UT+CP series Universal-joint Type Flat Spray/Solid Stream Nozzles..... p.19
- | QB series Quick-installation Standard Flat Spray Nozzles..... p.21
- | EJX series Ejector Nozzles for Solution Agitation..... p.23
- | TAIFUJet® series Air Booster Nozzles..... p.25
- | CCP-A series Air Nozzles Solid Stream Type..... p.29
- | HF series Air Nozzles Multi-orifice Flat Spray Type..... p.30
- | SLNHA-H series, SLNB series Air Nozzles Slit Type..... p.31
- | ARS Filter (Auto Reverse Self-cleaning Filter)..... p.32
- | Inquiry Form for Cooling System/Unit..... p.33

Appearance and dimensions of the products may slightly differ depending on product codes and materials.

Specifications of the products and contents of this catalog are subject to change without prior notice for purpose of product improvement.

# Spray Nozzle Uses in Automotive Manufacturing Processes

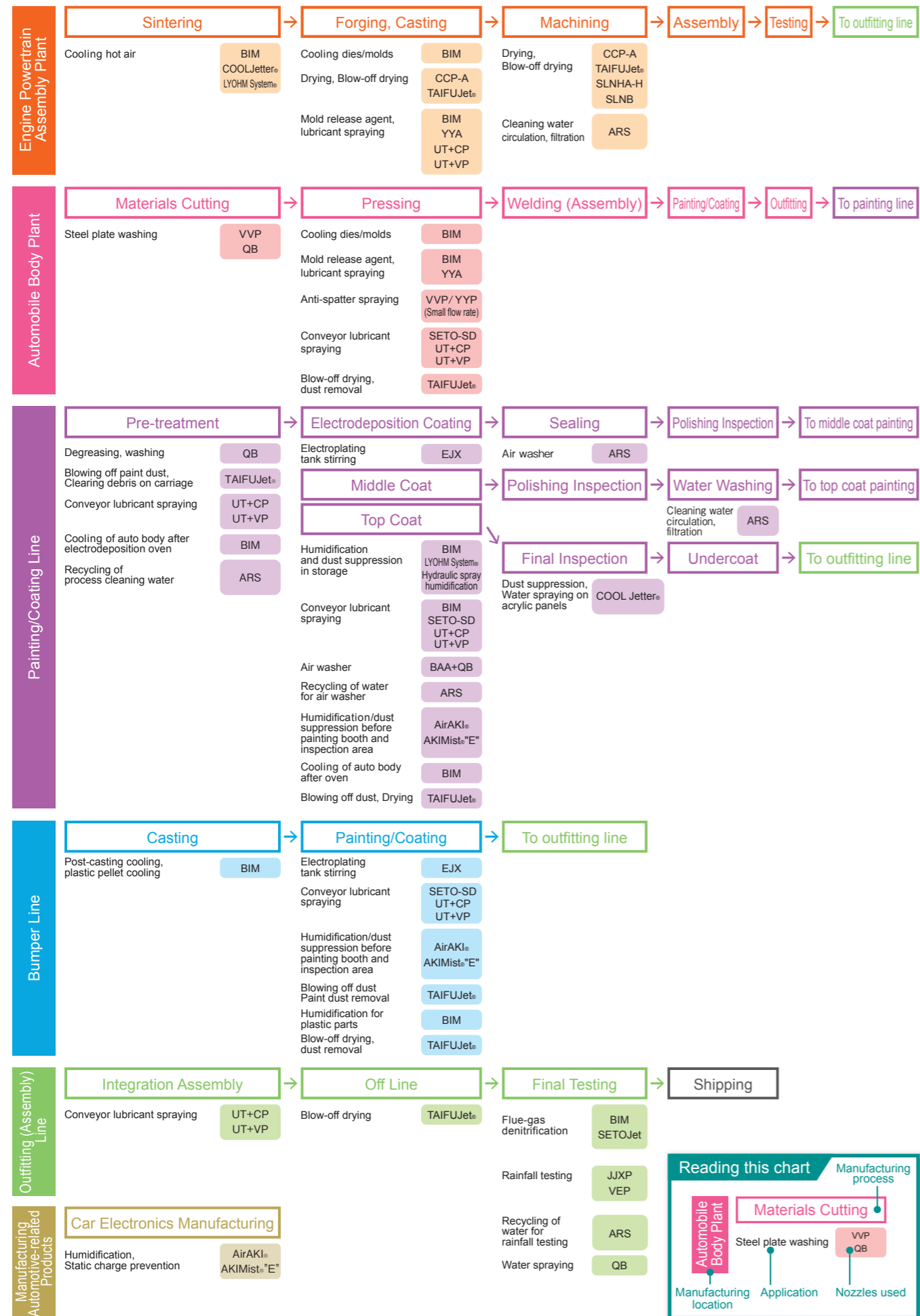

# How to Use This Catalog

## Cooling Systems, Cooling Units / Humidification Systems, Humidification Units

...p.5-8

Manufacturing process systems management must be more exacting to make even higher quality products. IKEUCHI introduces easy-to-use cooling and humidification systems and units to make complex systems management simpler.

## Spray Nozzle Product Line, Related Products

...p.9

This is an introduction to some representative examples of IKEUCHI spray nozzle uses, features, and performance charts. For more details, or information on our nozzles for general uses, please ask us for our comprehensive catalog.

## Example of Products Page

**1** Nozzle types, series

**2** Photo of nozzles

**3** Main features of nozzles

**4** Main process where the nozzles are used

**5** Production site/process where the nozzles are used, Main applications

**6** Spray pattern, Dimensional drawing, Structure, Materials, Specifications, etc. The unit for dimension is (mm).

**7** Nozzle selection chart (Spray performance)

**8** How to inquire / order

**Materials are described as follows in this catalog:**

	Description	Name of materials
Metal	S303	Stainless steel 303
	S304	Stainless steel 304
	S316	Stainless steel 316
	S316L	Stainless steel 316L
Rubber	FEPM	Tetrafluoroethylene-propylene rubber
	FKM	Fluororubber
	NBR	Nitrile rubber
Plastic resin	ABS	Acrylonitrile butadiene styrene
	HTPVC	Heat-treated polyvinyl chloride
	PP	Polypropylene
	FRPP	Glass-fiber reinforced polypropylene
	PPS	Polyphenylene sulfide
PVC	Polyvinyl chloride	
PTFE	Polytetrafluoroethylene	

**Description for thread size and type**  
 1/4M: 1/4" male taper pipe thread (R1/4)  
 1/4F: 1/4" female taper pipe thread (Rc1/4)  
 "M" denotes male thread and "F" denotes female thread.  
 Threads noted in this catalog are tapered pipe threads (PT) unless otherwise specified.

Only a part of our products is introduced in this catalog, but for plenty of more than 42,000 types, please ask for our catalogs of hydraulic spray nozzles and pneumatic spray nozzles including related equipments.

# Cooling Systems, Cooling Units

## Supporting systematic manufacturing management

By switching your spray cooling system to cooling units, it becomes even easier to manage processes and production with improved cooling and product quality.

### Desired measures and effects

Improving work environment	Measures against uneven cooling, leaks	Reducing costs
Work environment cooling (reducing heat) Shorten cycle times	Improve product quality and productivity Reduce defects	Reduce maintenance costs Improve energy savings

### Effective cooling matched to each use and process

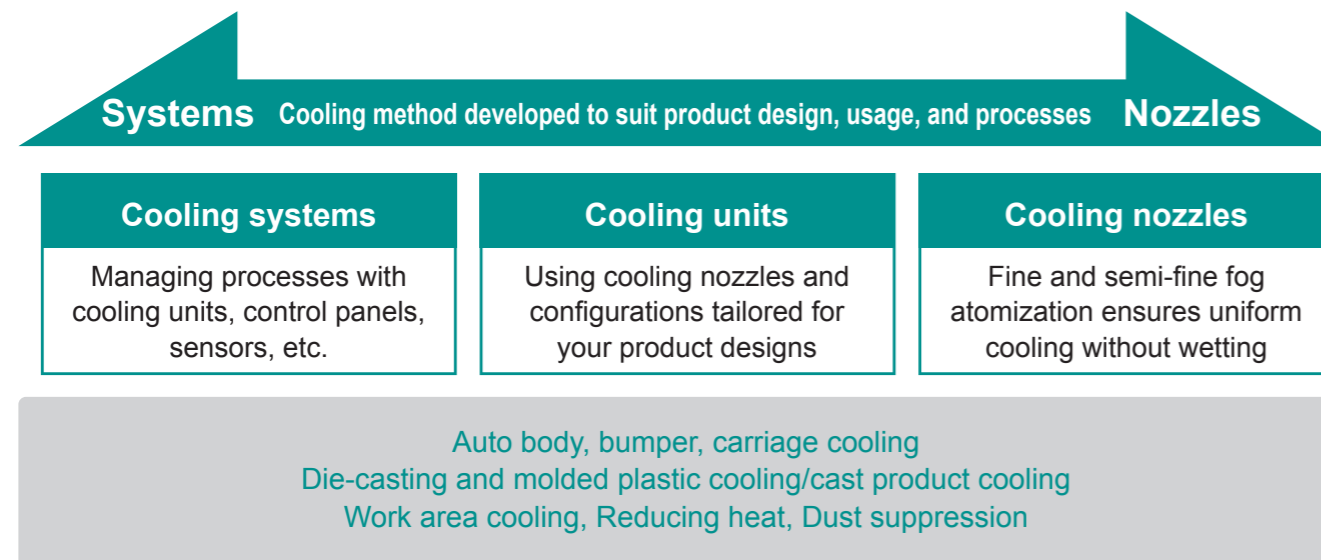

### Cooling capacity and performance of cooling system and unit

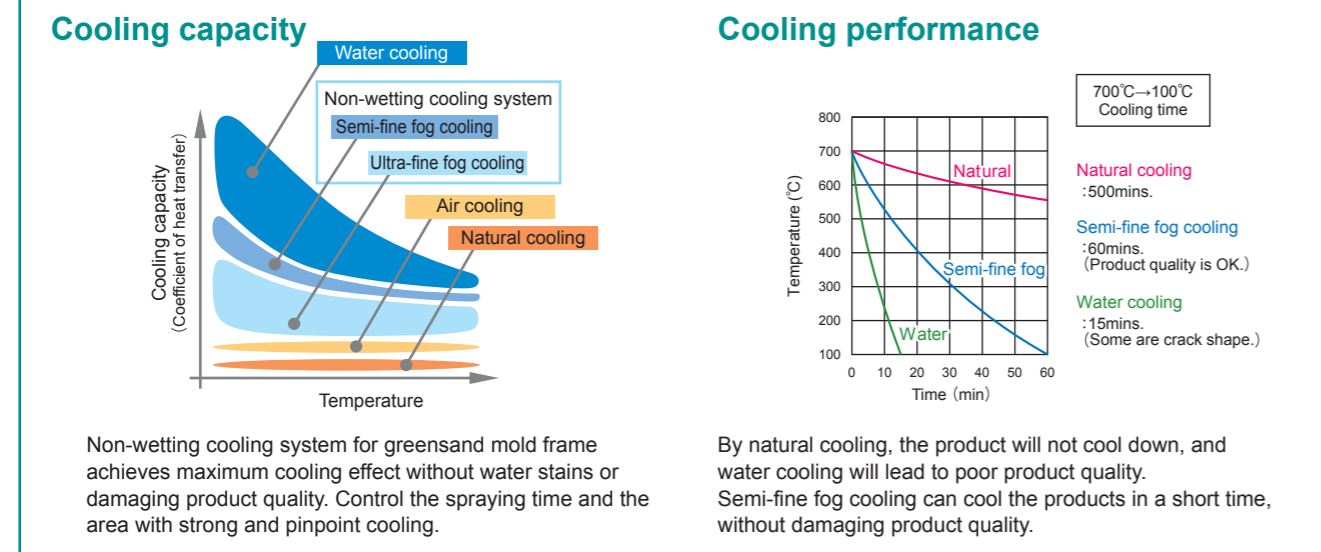

### Cast product cooling, Die cooling



- Replacing complicated equipment with small units matched to your die casting process makes installation and management easy.
- Rapid cooling, pinpoint cooling
- Optimized spray flow rate

#### Results

- Shortened cycle time
- Extended lifespan of dies
- Fewer defects

### Products cooling, Auto body cooling

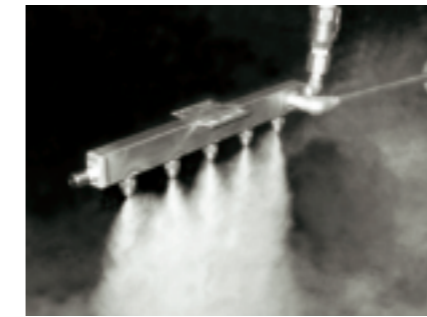

- Uniform spray distribution across entire spray area
- Control the spraying time and the area with strong and pinpoint cooling

#### Results

- Shortened cycle time
- Reducing uneven cooling
- Improving productivity, reducing defect rates

### Work area cooling, Dust suppression



- Wide range of cooling (cooling high temperature workplace)
- Energy-saving cooling in the area where wetting does not cause a problem

#### Results

- Improving work environment
- Cooling off heat (temperature reduction)
- Dust suppression

### Auto body\* cooling system diagram

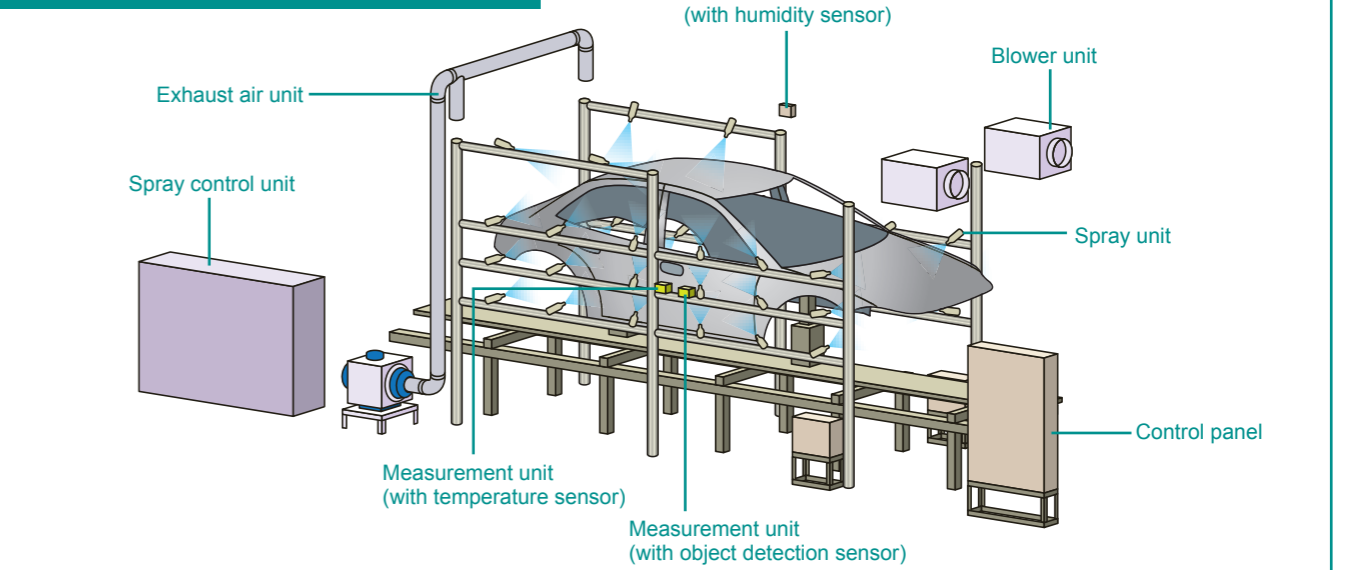

\*Automobile body

Inquiry form for cooling systems (units) is shown on page 33.

# Humidification Systems, Humidification Units

## Supporting systematic manufacturing management

It is common knowledge that proper humidity management is essential to the mounting process for the countless electronic components installed in automotive manufacturing. We are proud to provide Dry Fog humidification systems with the best track record in the industry, creating the proper humidity environment.

### Desired measures and effects

#### Static charge prevention

Reduce dust, debris adhesion  
Improve product quality and productivity

#### Better work environment

Work environment cooling (reducing heat)  
Shorten cycle times

#### Reducing costs

Reduce maintenance costs  
Reduce losses by decreasing defect rates

### Effective humidification matched to each use and process



### Static charge control and its effect by humidification systems

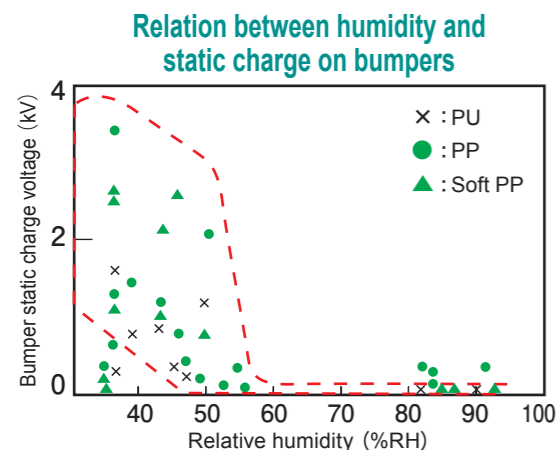

By keeping humidity at 55%RH or higher, the static charge on bumpers is reduced dramatically.

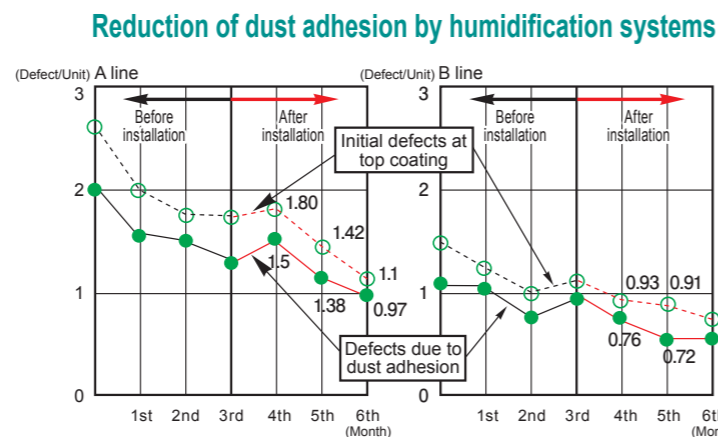

After installation of humidification system, defects due to dust adhesion and initial defects are reduced.

#### Humidification system AirAKI®



#### Dry Fog humidifier AKIMist®"E"



- Humidification systems create and maintain a stable humidity environment year-round
- Maintain the proper level of humidity for electronics mounting process for brake systems, car navigation, power windows, power steering as well as painting/coating processes

#### Results

- Reducing dust/debris adhesion
- Reducing mischucking
- Improved first run rates

#### Hydraulic spray humidification system LYOHM System®

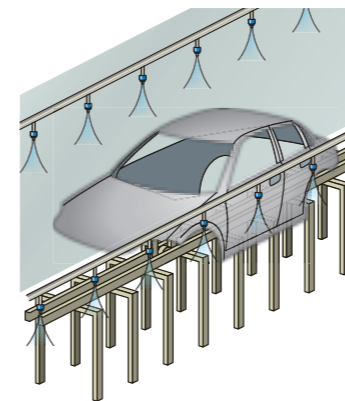

Humidification in storage

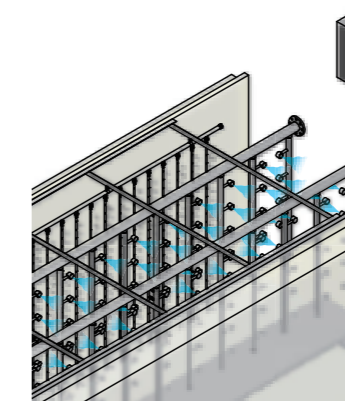

Humidification in air washer

- Hydraulic spray humidification/cooling system produces semi-fine atomization without using air
- Cost-saving humidification/cooling in the area where wetting does not cause a problem
- Prevent airborne dust in storage (spraying water without drenching floor)
- Cooling the work environment

#### Results

- Humidification
- Large reductions in cooling costs
- Cooling of workspaces
- Fog curtain for dust prevention at building and paint booth entryways

#### Humidification system installation & ancillary devices

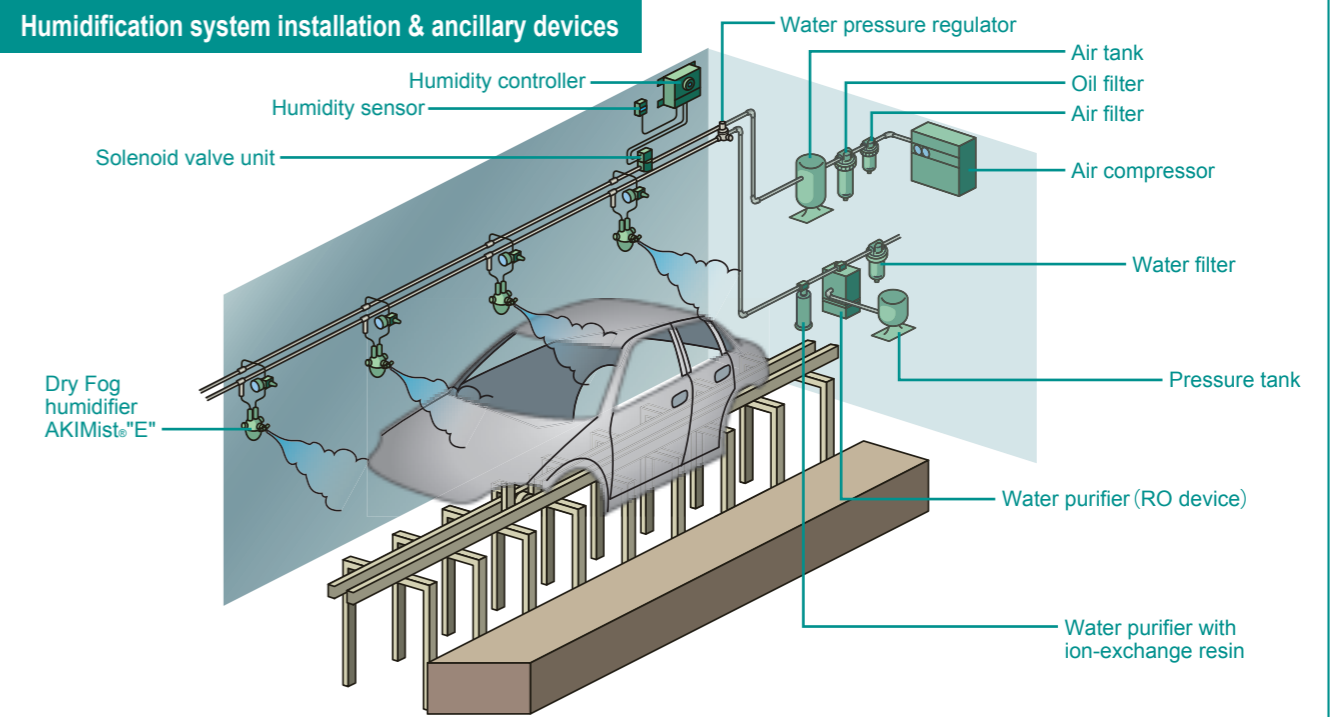

# Spray Nozzle Product Line, Related Products

## High-performance spray nozzles support improved product quality, productivity, and precision in processes

Our spray nozzles fill many roles of great importance, meeting the demands of manufacturing processes for better product quality, productivity, and efficiency.

### Nozzle uses and desired effects

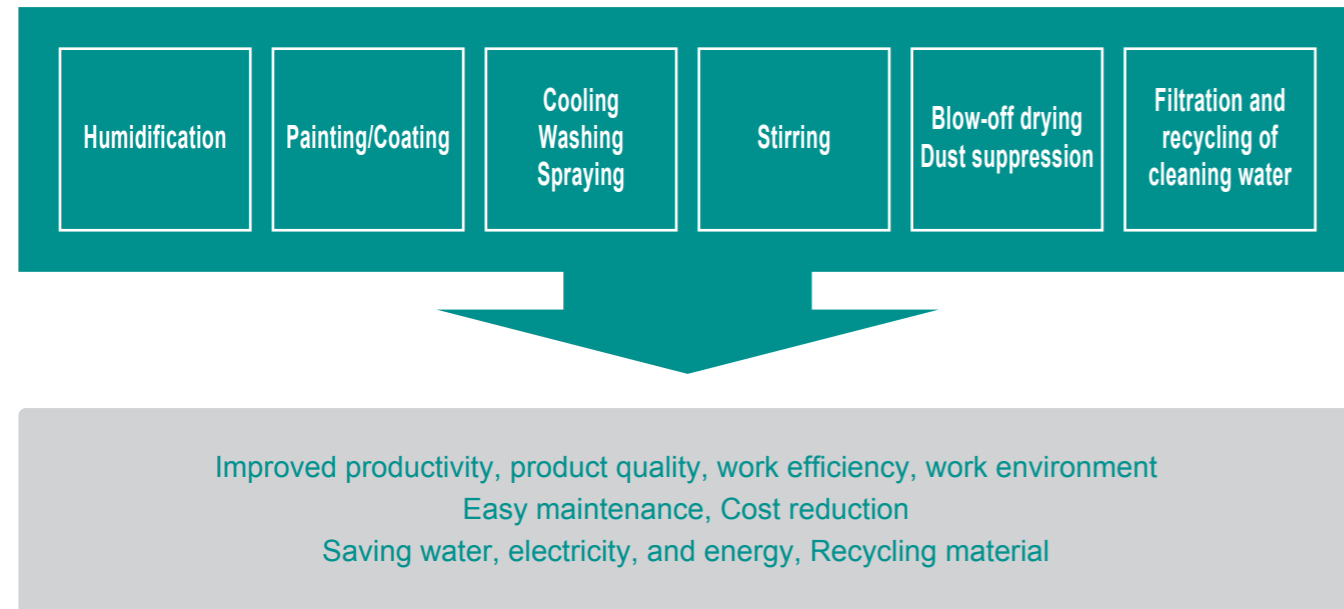

### Nozzle selection to match needs

<b>Pneumatic spray nozzles</b>	Pneumatic spray nozzles produce extremely fine droplets, especially effective in cooling, humidification, and coating. ➔ BIM series, AKIMist® "E", SETO-SD series, YYA series
<b>Hydraulic spray nozzles</b>	A huge selection of nozzle series for various processes and uses including washing, cooling, and spraying. ➔ UT+VP / UT+CP series, QB series, EJV series, and our standard hydraulic spray nozzles
<b>Air nozzles</b>	In painting, coating, and humidification, airborne dust and debris adhesion are sharply reduced. ➔ TAIFUJet®, CCP-A series, HF series, SLNHA-H series, SLNB series
<b>Related products</b>	Effective measures for recycling process water, removing impurities, and especially interesting when clean water resources are limited. ➔ ARS (Auto Reverse Self-cleaning) Filter

# Nozzles with Superior Controllability Solve Problems

## Pneumatic Fine Fog Spray Nozzles BIM series

Our "BIM series" have an especially wide range of control patterns compared to other pneumatic spray nozzles, meeting the needs of various uses and conditions. BIM series are pneumatic spray nozzles which produce extremely fine droplets with mean droplet diameters ranging from 10–100 μm. From fully or slightly wetting to even non-wetting spray, our nozzles can match a wide range of operating conditions.

We are proud to provide a diverse range of high-performance spray nozzles that are particularly well-suited to the demands of the automotive manufacturing industry.

### Features of BIM series

- High-performance**  
BIM series pneumatic spray nozzles produce particularly excellent atomization resulting in higher product quality.
- Easy maintenance, Uninterrupted use**  
IKEUCHI's unique designs are clog-resistant, allowing for long continuous spray periods.
- Diversity**  
Three types of spray patterns, two types of liquid feeding system, with various headers allow arrangements suited for a wide range of uses.
- Low price, Cost reduction**  
Compared with previous pneumatic spray nozzles, BIM series nozzles use fewer components, allowing for lower costs.
- Spray patterns in 3 types**  
Available in three spray patterns, flat spray (BIMV), hollow cone spray (BIMK), and full cone spray (BIMJ).

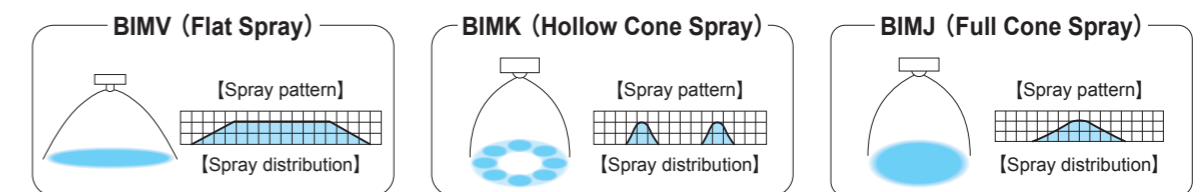

### Examples of nozzle uses

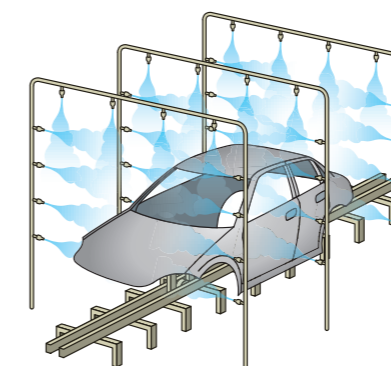

Cooling automobile bodies

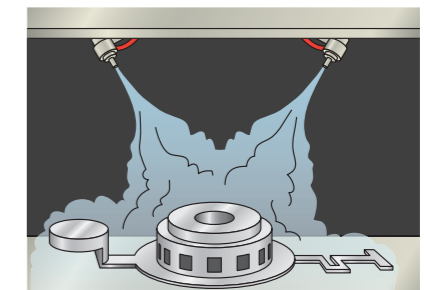

Cooling castings

# Pneumatic Fine Fog Spray Nozzles

BIM series

## BIM series Lineup

BIM series are available in liquid pressurized or liquid siphon feed type, with a choice of three types of spray patterns and eight types of adaptors.

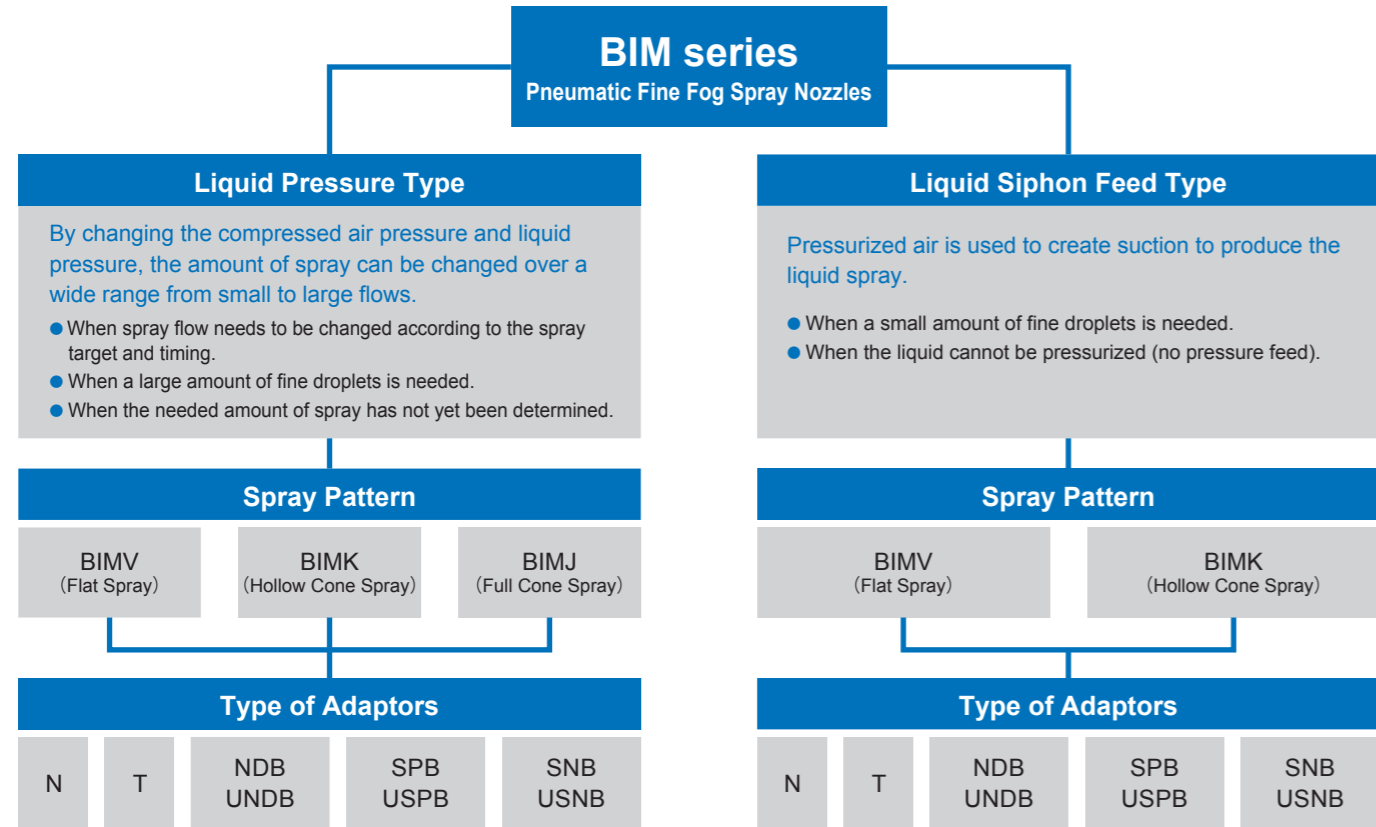

Details of adaptors are shown on page 14.

## BIM Series Specification (Extract)

Spray type	Series	Spray angle (°)	Compressed air pressure (MPa)	Spray capacity (ℓ/hr)*	Air consumption (ℓ/min, Normal)**	Mean droplet diameter (μm) Laser Doppler method	Spray pattern
				Liquid pressure (0.1–0.3 MPa)			
Small capacity Flat spray	BIMV	110·80·45	0.2–0.4	1.0 – 107	7 – 245	20–100	
Compact type, Small capacity Flat spray	CBIMV	110·80·45	0.2–0.4	0.5 – 38.5	5 – 91	20–100	
Ultra-compact type, Small capacity Flat spray	SCBIMV	110·80·45	0.2–0.4	0.25– 3.3	3.4– 9.6	20–100	
Small capacity Hollow cone spray	BIMK	60	0.2–0.4	2.0 – 107	13 – 245	20–100	
Compact type, Small capacity Hollow cone spray	CBIMK	60	0.2–0.4	2.0 – 38.5	13 – 91	20–100	
Small capacity Full cone spray	BIMJ	70·20	0.2–0.4	2.0 – 107	13 – 245	20–100	
Compact type, Small capacity Full cone spray	CBIMJ	20	0.2–0.4	0.5 – 38.5	5 – 91	20–100	
Ultra-compact type, Small capacity Full cone spray	SCBIMJ	20	0.2–0.4	0.25– 3.3	3.4– 9.6	20–100	

\*Measured at compressed air pressure of 0.3 MPa and liquid pressure of 0.1–0.3 MPa.

\*\*Measured at compressed air pressure of 0.2–0.4 MPa.

For detailed specifications, please refer to the catalog on pneumatic spray nozzles. CBIM series and SCBIM series are not shown in this catalog.

## Pneumatic Fine Fog Spray Nozzles

BIM series

### Examples of BIM nozzle uses

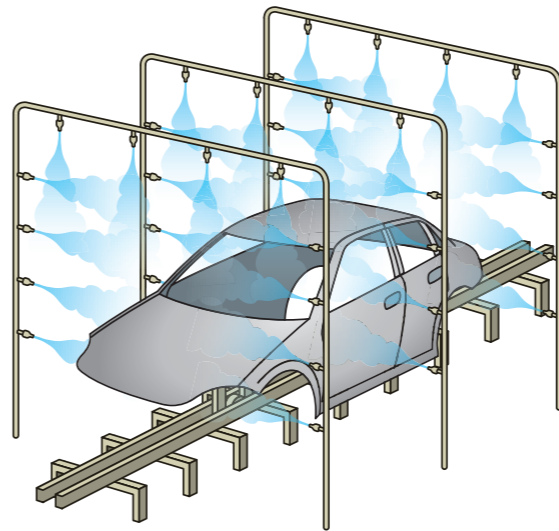

Automobile body cooling

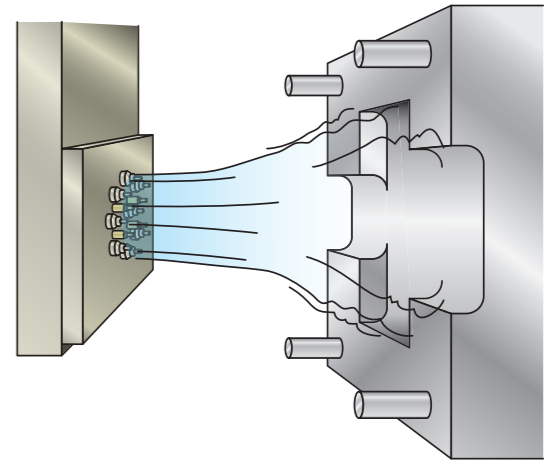

Mold release agent spraying system

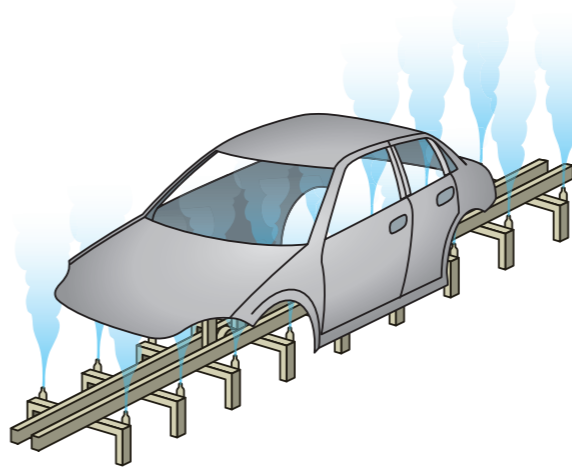

Carriage cooling

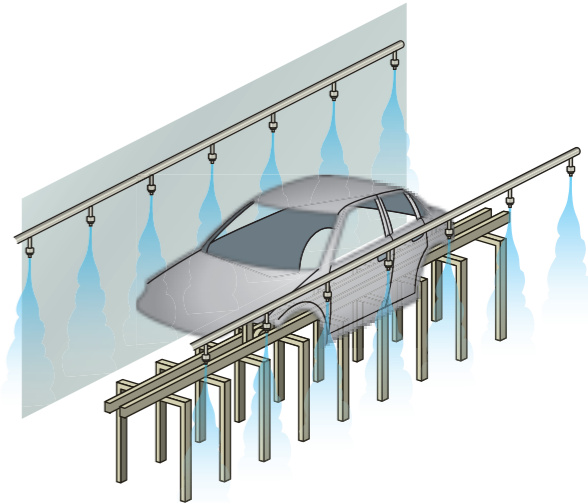

Humidification in storage

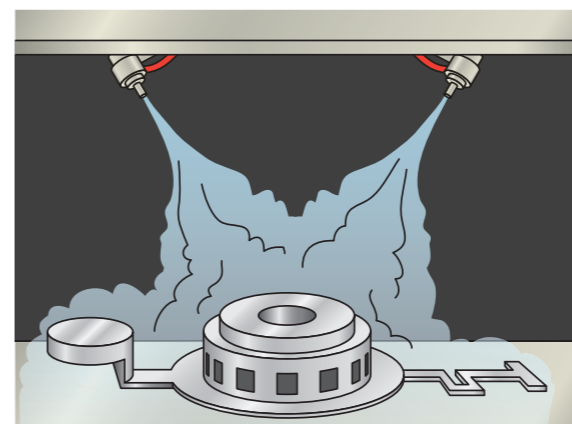

Cooling castings

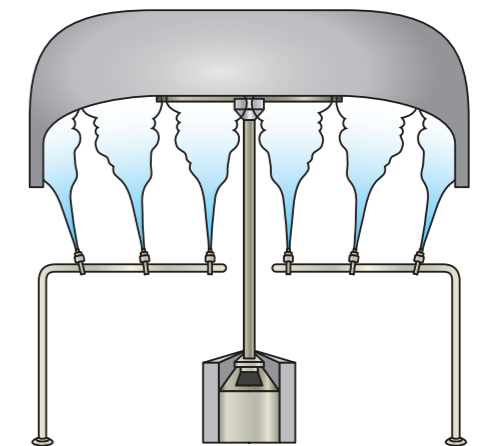

Bumper cooling



Features

- Produces fine atomization with a mean droplet diameter of 100 μm or less (measured by Laser Doppler Method).
- Clog-resistant design.
- Designed using fewer parts for easier maintenance and lower price.

Structure

- Comprising four parts: Spray tip, core, cap, and adaptor. (The structure and dimensions of adaptors are shown in our catalog on pneumatic spray nozzles)

Material

- S303, PP (PP is available only for BIMV80075 and BIMJ2004)  
Optional material: S316L

Applications



- Cooling of dies, metal castings, auto bodies, etc. in casting and coating processes
- Spraying of release agent, lubricant; rustproofing oil in forging, casting, and press processes
- Humidification and dust suppression in storage areas
- Dust suppression, humidification before the booth, cooling after the oven in painting/coating processes
- Cooling of plastics after forming, cooling of plastic pellets
- Cooling hot air from sintering, work environment improvement (reducing heat)

How to read the chart

- ① The spray capacity shown is for one nozzle.
- ② Red lines (—) represent compressed air pressure Pa in MPa.  
Blue lines (—) represent liquid pressure Pw in MPa.  
Green lines (—) represent air-water ratio Qa/Qw.
- ③ Figures in ovals ○ indicate Sauter mean droplet diameters (μm) measured by the Laser Doppler Method.
- ④ This flow-rate diagram is applicable to adaptor types of T and N only.

Flow-rate Diagram

BIMV8004

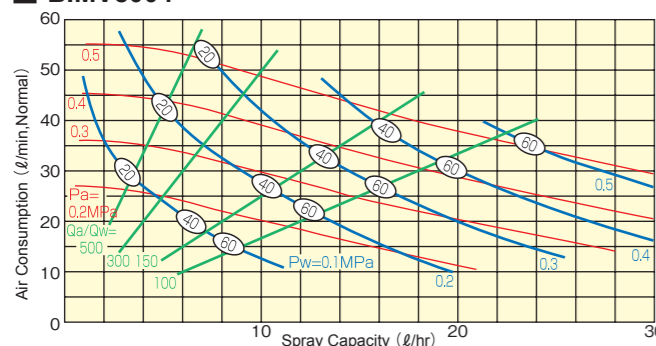

BIMV Performance Chart

Liquid pressure type BIMV (Flat spray)

Types of adaptors are shown on page 14.

Spray Angle Code *1	Air Consumption Code	Air Pressure (MPa)	Spray Capacity (l/hr) / Air Consumption (l/min, Normal)					Spray Coverage (mm) <sup>2</sup>			Mean Droplet Dia. (μm)	Free Passage Diameter (mm)		
			Liquid Pressure (MPa)					Liquid Pressure (MPa)				Spray Tip	Adaptor	
			0.1	0.15	0.2	0.25	0.3	0.1	0.15	0.25			Liquid	Air
02	0.2	2.2 / 14	5.3 / 11	—	—	—	200	260	—	20-100	0.3	0.9	0.7	
	0.3	1.0 / 20	2.5 / 19	4.6 / 17	8.3 / 12	14.3 / 7	170	210	300					
	0.4	—	1.4 / 25	2.3 / 24	4.0 / 23	6.3 / 20	—	200	250					
04	0.2	4.5 / 25	9.5 / 20	17.0 / 13	—	—	200	260	—	20-100	0.4	0.9	0.9	
	0.3	2.0 / 36	4.7 / 35	8.5 / 31	13.1 / 27	19.6 / 20	170	210	310					
	0.4	—	2.8 / 45	4.8 / 44	7.7 / 41	11.4 / 37	—	200	260					
80	0.2	8.7 / 51	18.4 / 42	33.3 / 29	—	—	200	270	—	20-100	0.6	1.2	1.4	
	0.3	4.0 / 74	8.8 / 71	15.5 / 64	24.3 / 54	38.5 / 40	170	210	310					
	0.4	—	5.6 / 91	9.1 / 89	14.8 / 82	21.8 / 74	—	200	260					
15	0.2	16.8 / 107	34.8 / 90	64.4 / 60	—	—	210	280	—	20-100	0.9	1.8	1.9	
	0.3	8.0 / 150	17.7 / 144	30.8 / 130	50.0 / 108	74.5 / 87	180	220	320					
	0.4	—	11.2 / 190	18.3 / 183	29.1 / 172	42.9 / 154	—	200	270					
22	0.2	22.3 / 140	45.6 / 116	92.1 / 77	—	—	210	280	—	20-100	1.1	2.1	2.2	
	0.3	11.5 / 200	23.9 / 189	41.3 / 169	68.5 / 138	107 / 103	180	220	330					
	0.4	—	15.3 / 245	24.5 / 238	39.1 / 220	57.7 / 198	—	210	280					

\*1) Spray angle is measured at compressed air pressure of 0.3 MPa and liquid pressure of 0.1 MPa. \*2) Spray coverage is measured at 100 mm from nozzle.

How to inquire / order

Please inquire or order for a specific nozzle using this coding system.

<Example> BIMV 8004 S303 + NS303

**BIMV**    **80**    **04**    **S303**    +    **N**    **S303**

Spray Angle Code    Air Consumption Code    Type of Adaptor

- 110    02    N
- 80    04    T
- 45    075    NDB
- 15    15    UNDB
- 22    22    USNB

For the specifications of BIMV flat spray nozzles with other spray angle types and for BIMJ full cone spray nozzles and BIMK hollow cone spray nozzles, please refer to the catalog on pneumatic spray nozzles.

Types and Structures of Adaptors

type N

Liquid and air enter into adaptor from both sides.

type T

Air inlet is on the center line and liquid inlet is on a 90° angle line to the center line. Suitable for use in a small space.

type NDB

Spray capacity is adjustable with needle valve.

type UNDB

Besides the features of the NDB-type adaptor, spray direction can be adjusted within +/-15° by means of a ball joint. It is ideal for fine-tuning of spray direction after pipe assemblies have been completed.

type SPB

Spray (ON/OFF) can be regulated by switching the pilot air ON/OFF. The pilot air actuates an internal piston to regulate the spray. (Pilot air pressure more than 0.2 MPa required) Suitable for applications to avoid scattering droplets of fog.

type USPB

Besides the features of the SPB-type adaptor, spray direction can be adjusted within +/-15° by means of a ball joint. It is ideal for fine-tuning of spray direction after pipe assemblies have been completed.

type SNB

Spray (ON/OFF) can be regulated by turning compressed air ON/OFF, which actuates an internal piston, to open or close the nozzle. Compressed air pressure over 0.2 MPa starts the spray.

type USNB

Besides the features of the SNB-type adaptor, spray direction can be adjusted within +/-15° by means of a ball joint. It is ideal for fine-tuning of spray direction after pipe assemblies have been completed.

Mounting Bracket

- Mounting bracket enables easy fixing of a nozzle on a pole with desired spray direction.
- Available for the adaptor types T, NDB (UNDB), SPB (USPB), and SNB (USNB). Note: Not available for N-type adaptor.
- Available in two sizes for pipe diameters of 8 mm and 10 mm.



BIM Integrated Spray Header

Integrated BIM fine fog spray header combining compressed air and water pipes into one rectangular header. Very compact and easy for installation and maintenance.

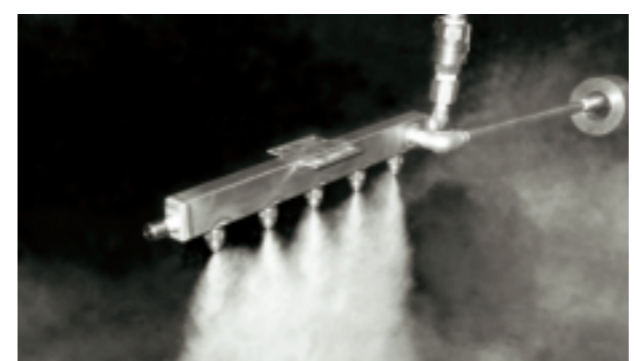

Spray Controller

This houses the control equipment. Controls include ON/OFF timer or automated control with signal inputs.





# Dry Fog Humidifiers

Patent pending

AKIMist® "E"

## Features

- Large volume of Dry Fog as maximum 9.6 l/hr is generated.
- Maintenance is easy as the nozzle can be easily detached by hand.
- Dry Fog reaches over four meters horizontally, providing effective humidification.

## Applications

Painting/Coating Inspection area Storage Bumper painting Manufacturing automotive-related products

- Humidification and dust suppression before painting booth and in inspection areas
- Humidification and prevention of static charge in car electronics manufacturing processes

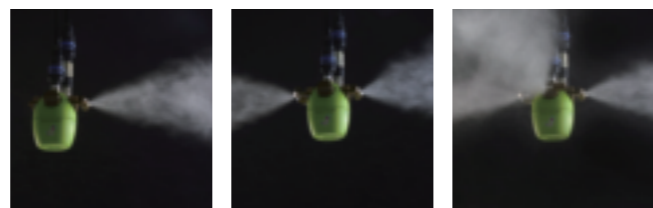

## Dimensions

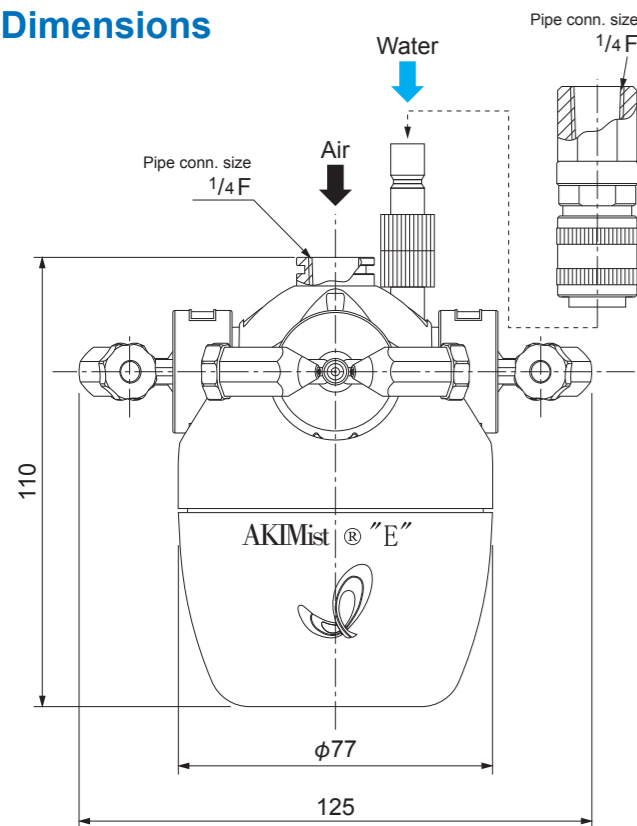

## Specifications

Model No.	Number of nozzles	at compressed air pressure of 0.3 MPa (44 psi)	
		Spray volume l/hr (GPH)	Air consumption l/min, Normal (SCFM)
AE-1 (03C)	1	2.4 (0.63)	29 (1.08)
AE-2 (03C)	2	4.8 (1.27)	58 (2.16)
AE-3 (03C)	3	7.2 (1.90)	87 (3.24)
AE-4 (03C)	4	9.6 (2.54)	116 (4.32)

### Note:

- 1) Use under the compressed air pressure of between 0.2 and 0.5 MPa (29 and 73 psi) and the water pressure of between 0.05 and 0.2 MPa (8 and 29 psi).
- 2) Before disassembly, close the water valve to prevent water leakage.
- 3) As main parts are made of plastic, handle AKIMist® "E" with care. (For details, see the instruction manual.)

**Materials** •Body: PP, S303  
•Nozzle: S303, PPS, PTFE  
•O-ring: NBR, FKM  
•Packing: NBR

**Mass** Approx. 340 g (Loaded)

For details, our catalog of AKIMist® "E" is available.

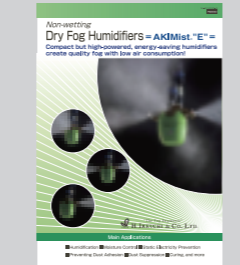

## How to inquire / order

Please inquire or order for a specific model using this coding system.

<Example> AE-1 (03C) + [Hanging-down Kit]

If a pipe connection kit is required, please specify the connection kit type at + [ ].

**AE- 1 (03C) + Hanging-down Kit**

**Number of Nozzles**

- 1
- 2
- 3
- 4

### Type of Pipe Connection Kits

- Standard Kit
- Hanging-down (NP) Kit (without plate)
- Wall Mounting Kit
- Hanging-down Kit

## Dry Fog Humidifiers

AKIMist® "E"

### Pipe Connection Kits (optional) for easy installation of AKIMist® "E"

Standard Kit	Hanging-down (NP) Kit (w/o plate)	Wall Mounting Kit	Hanging-down Kit
<ul style="list-style-type: none"> <li>• This kit is shipped in pieces and is to be assembled by customers.</li> <li>• 1/4M threaded connection.</li> </ul>	<ul style="list-style-type: none"> <li>• This kit is assembled before shipment.</li> <li>• 1/4F threaded connection.</li> </ul>	<ul style="list-style-type: none"> <li>• This kit is assembled before shipment.</li> <li>• Bolts for fixing mounting plate are not included and to be prepared by customers.</li> <li>• The diameters of holes on the plate are 9 mm.</li> <li>• 1/4F threaded connection.</li> </ul>	<ul style="list-style-type: none"> <li>• This kit is assembled before shipment.</li> <li>• Bolts &amp; hanging fixture are not included and to be prepared by customers.</li> <li>• The diameter of hole on the plate is 11 mm.</li> <li>• 1/4F threaded connection.</li> </ul>

Note: Gray parts are NOT included in the kit.

## Optional product

### AE-UT Adaptor for AKIMist® "E"

AE-UT Adaptor enables you to adjust spray direction as desired, just by installing it between the nozzle and the humidifier body. You can easily attach and remove it by hand.

Note: Stop spraying before you change the direction.



## Dry Fog Humidifier Kit

### AKIMist® "E" AE-KIT

All the components for an efficient humidification system in an easy DIY kit

No complicated setup needed: just supply the electricity and compressed air. High-performance humidification system at affordable price.

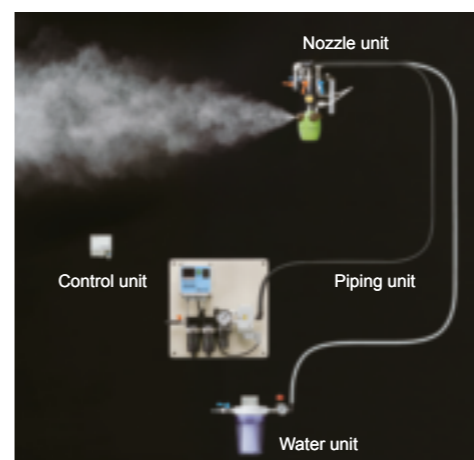

Includes Nozzle unit (AKIMist® "E"), Control unit, Water (filter) unit, and Piping unit.

Please contact us for an inquiry sheet.

## Portable Dry Fog Humidifier Set

### AKIMist® "E" AE-T set

No piping work necessary. AKIMist® "E" portable humidifier set with a stand unit and water pressure tank for immediate usage in any place with a compressed air supply.



# Solenoid-activated Pneumatic Spray Nozzles

Patented  
SETO-SD series

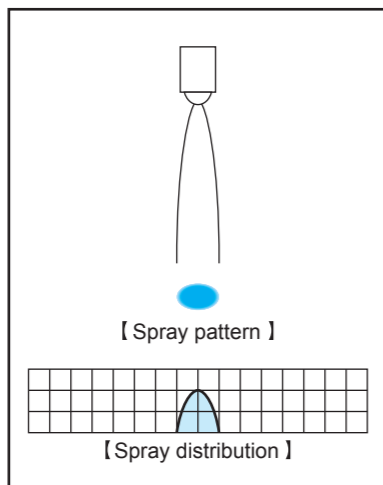

## Features

- Fast response performance by solenoid activation: Intermittent pulse spray at 0.02 sec/1 shot with a minimum of 0.006 cc/shot is possible.
- Ideal for coating in small amounts, i.e. protective agent coating, etc.
- IP65, IP67 (dust-proof and water-proof) structure.

## Applications

- Casting Pressing Painting/Coating Bumper painting
- Spraying release agent for engine chassis and other metal casting processes
  - Intermittent spraying with minimal spray amount in paint/coating process (uniform coating without dripping)
  - Spraying conveyor lubricant

## Structure & Materials

### Components and materials

No.	Components	Main materials
①	Nozzle body	Stainless steel, Aluminum
②	Adaptor	Aluminum
③	Solenoid	

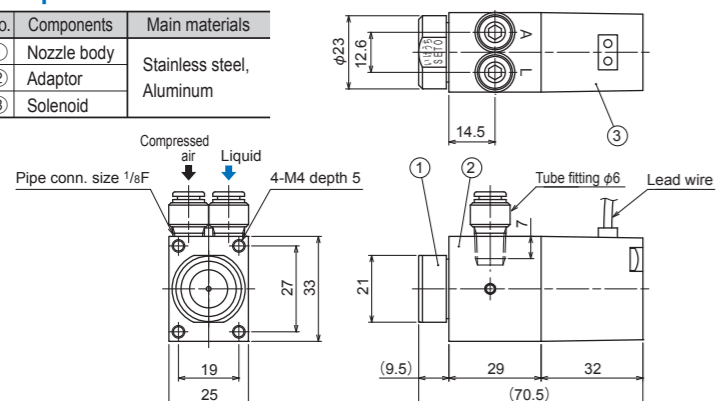

## How to Use

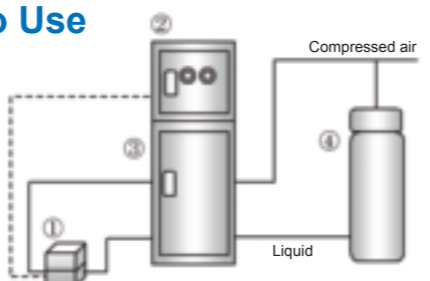

No.	Description
①	Solenoid-activated pneumatic spray nozzle
②	Solenoid control panel
③	Pressurized flow control unit
④	Liquid pressurization tank (required only if oil-based release agent is used)

## Spray Performance

Nozzle Code	Air Pressure (MPa)	Spray Capacity (ℓ/hr) / Air Consumption (ℓ/min, Normal) *1					Spray Width *2 (mm)	Mean Droplet Diameter *3 (μm)	Free Passage Diameter (mm)		Mass (g)	
		Liquid Pressure (MPa)							Liquid	Air	Aluminum	S304
07503R-I	0.2	-	-	1.0/50	3.2/48	-	40-50	20-100	0.3	0.4	180	270
	0.3	-	-	-	0.9/66	4.0/64						
	0.4	-	-	-	-	1.9/80						
0405R	0.3	2.0/ 36	6.5/ 36	-	-	-	15-25	0.5	0.1	180	270	
07507R		5.0/ 71	13.9/ 71	-	-	-						
2210R		10.0/200	26.4/200	-	-	-						

\*1) Spray capacity and air consumption at liquid pressure of 0 MPa (liquid siphon feed) are measured at 100 mm siphon height.  
\*2) Spray width is measured at a spray distance of 100 mm.  
\*3) Sauter mean droplet diameters are measured at compressed air pressure of 0.3 MPa and liquid pressure of 0 MPa (liquid siphon feed) by Laser Doppler method.

Valve Function	Min. Operating Frequency (sec)	Max. Operating Pressure (MPa)	Electric Current (A)	Electric Voltage (VDC)	Max. Allowable Temperature
Single solenoid, normally closed	ON: 0.02 OFF: 0.02	0.5 for both air/liquid	0.26	24	50°C (120°F)

**How to inquire / order** Please inquire or order for a specific nozzle using this coding system.

<Example> SETO 07503R-I +SD AL  
**SETO 07503R-I + SD AL**  
 Nozzle Code: 07503R-I, 0405R, 07507R, 2210R  
 Material: AL (Aluminum), S304

# Wide-angle Flat Pneumatic Spray Nozzles

Patented  
YYA series



## Features

- 2-step atomization mechanism enables a wide spray angle of 80°.
- Combines "clog-resistant" and "wide spray angle" features.
- Compact, 22mm-long design helps in downsizing of equipment.
- Capable of spraying viscous liquid (up to approx.300cP). \*1

\*1) Spray capacity and spray angle are reduced when viscous liquid is sprayed. Raising the liquid pressure to 0.2-0.3 MPa is recommended when spray capacity is small, otherwise the spray pattern becomes irregular.

## Applications

- Casting Pressing
- Spraying mold release agent in casting process for cast products and engines
  - Spraying mold release agent/lubricant in body pressing process

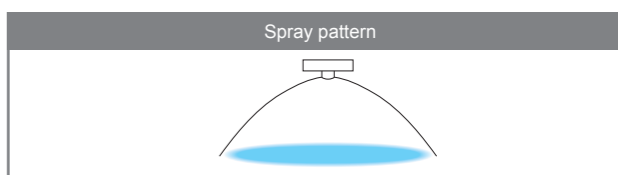

## 2-step atomization mechanism

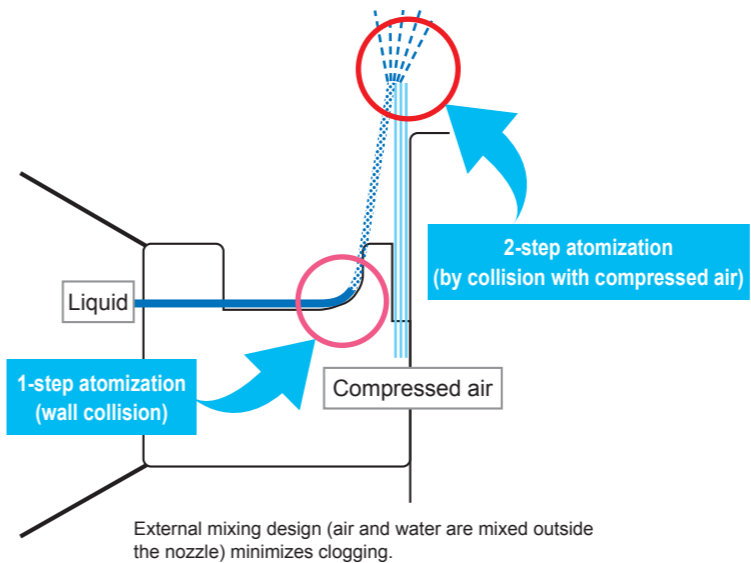

## Dimensions

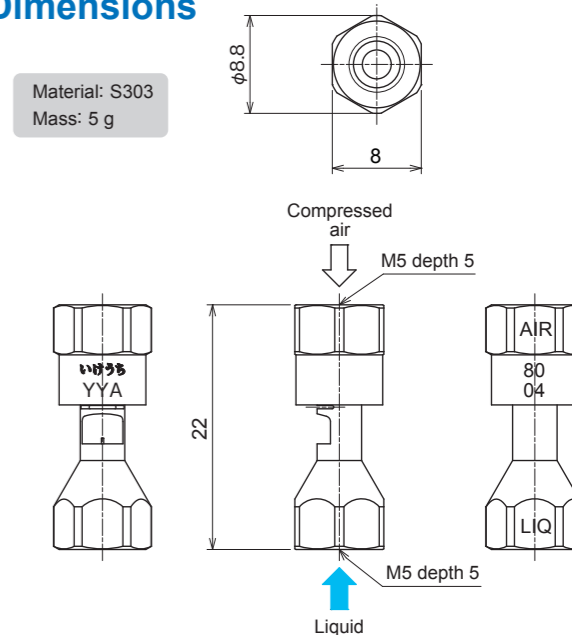

## Spray Performance

Spray Angle Code*2	Air Consumption Code	Air Pressure (MPa)	Air Consumption (ℓ/min, Normal)	Spray Capacity (ℓ/hr)				Spray Coverage (mm) <sup>3</sup>				Mean Droplet Diameter (μm)	Free Passage Diameter (mm)					
				Liquid Pressure (MPa)				Liquid Pressure (MPa)					Liquid	Air				
80	04	0.2	27	2.2	5.0	7.1	10.0	0.01	0.05	0.1	0.2	160	170	170	-	15-30	0.4	0.2
		0.3	36					170	170	180	190							
		0.4	45					170	180	190	200							
		0.5	54					180	180	200	210							

\*2) The above spray angle is measured at compressed air pressure of 0.3 MPa and liquid pressure of 0.05 MPa.  
\*3) The above spray coverage is measured at a spray distance of 100 mm.

**How to inquire / order** Please inquire or order for a specific nozzle using this coding system.

**M5F YYA 80 04 S303**

# Universal-joint Type Flat Spray Nozzles

UT+VP series

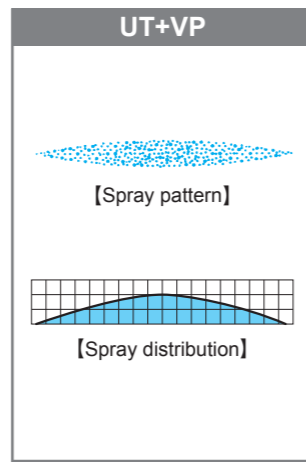

### Features

- Flat spray pattern with a mountain-shaped spray distribution having gradually tapered edges.
- Spray direction is adjustable over range of 40 degrees as desired.
- Standard pressure: 0.3 MPa

### Applications

- Casting** **Pressing** **Painting/Coating**
- Bumper painting**
- Spraying conveyor lubricant in casting, pressing, pre-coating processes

## Dimensions

		UT+VP series										Mass (g)
Pipe Conn. Size	Structure	Dimensions (mm)										
		L <sub>1</sub>	L <sub>2</sub>	H <sub>1</sub>	H <sub>2</sub>	W	D <sub>1</sub>	D <sub>2</sub>	D <sub>3</sub>	N		
1/4M	• Three-piece structure with ceramic orifice inserted. • Comprises three parts: Nozzle, cap, and adaptor. • Nozzle unit has integrated universal ball joint for adjusting spray direction.	57.5	37	29	24	11	32	26.5	13	10.5	120	
3/8M		63.5	44	35	30	14	38.5	33	17	11	200	

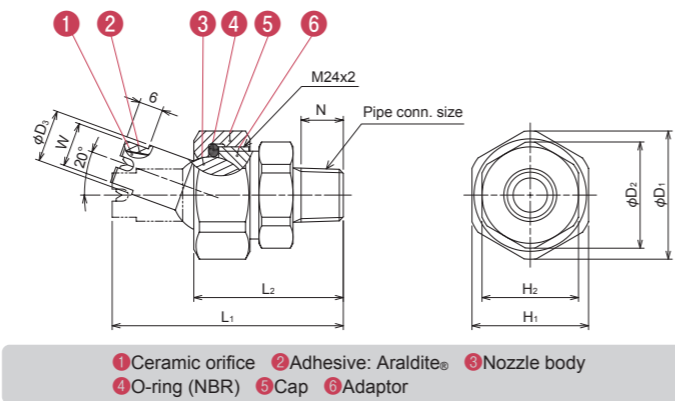

- 1 Ceramic orifice 2 Adhesive: Araldite® 3 Nozzle body
- 4 O-ring (NBR) 5 Cap 6 Adaptor

## Spray Performance

Spray Angle Code	Spray Capacity Code	Pipe Conn. Size		Spray Angle (°)			Spray Capacity (ℓ/min)								Free Passage Diameter (mm)
		1/4M	3/8M	0.15 MPa	0.3 MPa	0.7 MPa	0.1 MPa	0.15 MPa	0.2 MPa	0.3 MPa	0.5 MPa	0.7 MPa	1 MPa	2 MPa	
80	30	○		70	80	87	1.73	2.12	2.45	3.00	3.88	4.58	5.48	7.75	1.0
	50	○		71	80	86	2.89	3.54	4.08	5.00	6.46	7.64	9.13	12.9	1.4
	80	○		72	80	86	4.62	5.66	6.53	8.00	10.3	12.2	14.6	20.6	1.7
	100		○	72	80	85	5.77	7.07	8.17	10.0	12.9	15.3	18.3	25.8	2.0
	140		○	73	80	85	8.08	9.90	11.4	14.0	18.1	21.4	25.6	36.1	2.5
65	170		○	73	80	85	9.82	12.0	13.9	17.0	22.0	26.0	31.1	43.9	2.7
	30	○		56	65	72	1.73	2.12	2.45	3.00	3.88	4.58	5.48	7.75	1.1
	50	○		57	65	71	2.89	3.54	4.08	5.00	6.46	7.64	9.13	12.9	1.5
	80	○		58	65	71	4.62	5.66	6.53	8.00	10.3	12.2	14.6	20.6	1.9
	100		○	58	65	70	5.77	7.07	8.17	10.0	12.9	15.3	18.3	25.8	2.1
50	140		○	59	65	69	8.08	9.90	11.4	14.0	18.1	21.4	25.6	36.1	2.5
	170		○	59	65	69	9.82	12.0	13.9	17.0	22.0	26.0	31.1	43.9	2.8
	30	○		42	50	56	1.73	2.12	2.45	3.00	3.88	4.58	5.48	7.75	1.2
	50	○		43	50	55	2.89	3.54	4.08	5.00	6.46	7.64	9.13	12.9	1.6
	80	○		43	50	55	4.62	5.66	6.53	8.00	10.3	12.2	14.6	20.6	2.0
50	100		○	44	50	54	5.77	7.07	8.17	10.0	12.9	15.3	18.3	25.8	2.2
	140		○	44	50	54	8.08	9.90	11.4	14.0	18.1	21.4	25.6	36.1	2.7
	170		○	45	50	54	9.82	12.0	13.9	17.0	22.0	26.0	31.1	43.9	3.0

Note: 1. For spray droplet diameter, please refer to VVP/VP series performance chart in the hydraulic spray nozzles catalog.  
2. Spray nozzle performance is guaranteed only when the nozzle is set at no angle.

### How to inquire / order

Please inquire or order for a specific nozzle using this coding system.

<Example> 1/4M UT+VP 8030 S303

1/4M (Pipe Conn. Size) UT+VP 80 (Spray Angle Code) 30 (Spray Capacity Code) S303

80 65 50 (Spray Angle Code)  
30 - 170 (Spray Capacity Code)

# Universal-joint Type Solid Stream Jet

UT+CP series

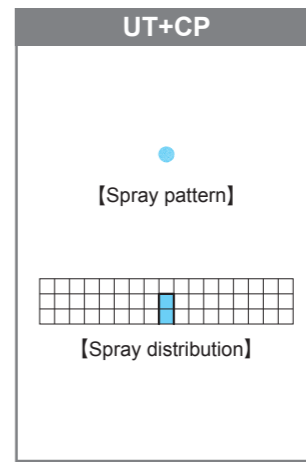
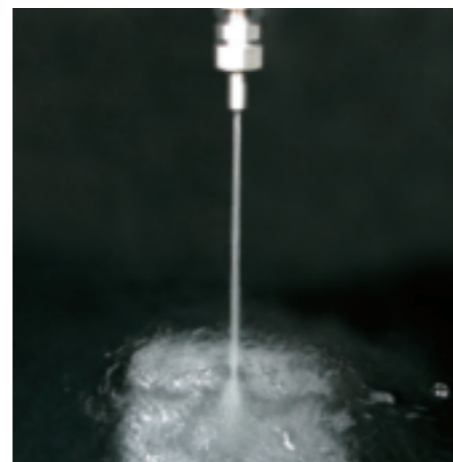

### Features

- High impact solid stream.
- Internal design keeps flow resistance to a minimum, yielding large volume flow.
- Spray direction is adjustable over range of 40 degrees as desired.
- Standard pressure: 0.3 MPa

### Applications

- Casting** **Pressing** **Painting/Coating**
- Bumper painting**
- Spraying conveyor lubricant in casting, pressing, pre-coating processes

## Dimensions

		UT+CP series									
Pipe Conn. Size	Structure	Dimensions (mm)									
		L <sub>1</sub>	L <sub>2</sub>	H <sub>1</sub>	H <sub>2</sub>	W	D <sub>1</sub>	D <sub>2</sub>	D <sub>3</sub>	N	
1/4M	• Three-piece structure with ceramic orifice inserted. • Comprises three parts: Nozzle, cap, and adaptor. • Nozzle unit has integrated universal ball joint for adjusting spray direction.	57.5	37	29	24	11	32	26.5	13	10.5	120
3/8M		63.5	44	35	30	14	38.5	33	17	11	200

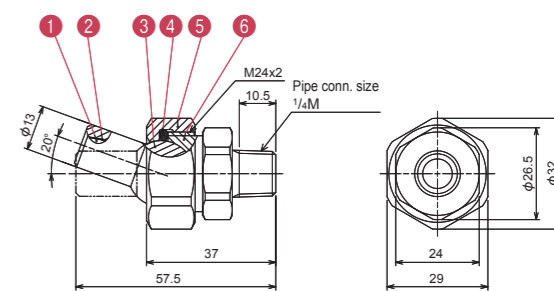

- 1 Ceramic orifice 2 Adhesive: Araldite® 3 Nozzle body
- 4 O-ring (NBR) 5 Cap 6 Adaptor

## Spray Performance

Spray Capacity Code	Spray Capacity (ℓ/min)								Free Passage Diameter (mm)
	0.1 MPa	0.15 MPa	0.2 MPa	0.3 MPa	0.5 MPa	0.7 MPa	1 MPa	2 MPa	
30	0.68	0.83	0.96	1.17	1.51	1.79	2.14	3.03	1.0
37	0.90	1.10	1.28	1.56	2.02	2.39	2.86	4.04	1.2
49	1.47	1.80	2.08	2.54	3.28	3.88	4.65	6.56	1.5
80	2.03	2.48	2.87	3.51	4.53	5.36	6.43	9.09	1.8
111	2.48	3.04	3.51	4.30	5.55	6.57	7.85	11.1	2.0
136	4.51	5.52	6.38	7.81	10.1	11.9	14.3	20.2	2.6
247	5.88	7.20	8.31	10.2	13.1	15.6	18.6	26.3	3.0
322	8.12	9.95	11.5	14.1	18.2	21.5	25.7	36.3	3.5

Note: Precision guarantee for UT+CP series is only for spray angle (its axis of spray direction is within 3° from nozzle body centerline).

### How to inquire / order

Please inquire or order for a specific nozzle using this coding system.

<Example> 1/4M UT+CP 37 S303

1/4M (Pipe Conn. Size) UT+CP 37 (Spray Capacity Code) S303

37 - 445 (Spray Capacity Code)

# Quick-installation Standard Flat Spray Nozzles QB series

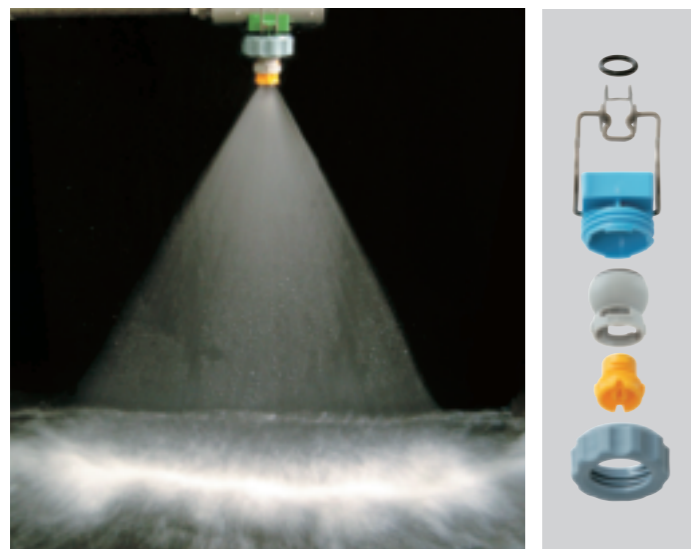

### Features

- Quick installation just by drilling a hole on a pipe and inserting a nozzle.
- O-ring seals between pipe and adaptor for pressures up to 0.4 MPa.
- Adjust spray direction within 50 degrees as desired. Spray tips are color-coded by spray capacity for easy identification.
- Caps are shared by all sizes.
- Quick detachable nozzle reduces maintenance time.
- Double locked by fitting spring lock (option).
- Adaptors available in two types for metal piping and PVC piping.

### Applications

Materials cutting   Pre-treatment   Final testing

- Degreasing, washing for preprocessing in painting process
- Easy maintenance of spray nozzles
- Steel plate washing in body material cutting process

## Dimensions

QB series	
<b>Structure</b>	• Comprises three parts: Nozzle, Ball, and Adaptor. • Worn-out nozzle can be replaced separately.
<b>Material</b>	• Main parts: FRPP

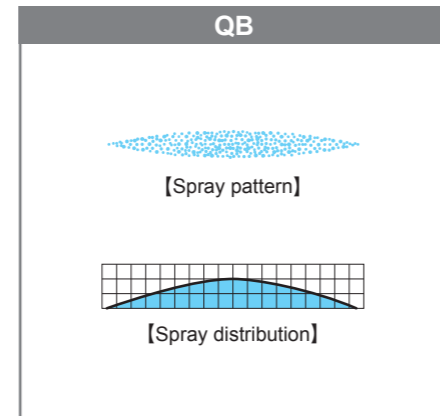

### [QB for metal pipes]

Pipe Size (inch)	Color of Adaptor	Dimensions (mm)						Mass (g)
		L <sub>1</sub>	L <sub>2</sub>	L <sub>3</sub>	L <sub>4</sub>	φD <sub>1</sub>	φD <sub>2</sub>	
1	Blue	105	89	72	55	34	48	61
1*1/4	Green	114	98	76	55	42.7	48	
1*1/2	Yellow	120	104	79	55	48.6	48	
2	Orange	132	116	85	55	60.5	48	

Pipes should be stainless steel pipes compliant with JIS G 3459.

### [QB for PVC pipes]

Pipe Size (ND) <sup>1)</sup>	Color of Adaptor	Dimensions (mm)						Mass (g)
		L <sub>1</sub>	L <sub>2</sub>	L <sub>3</sub>	L <sub>4</sub>	φD <sub>1</sub>	φD <sub>2</sub>	
25A	Blue	103	87	71	55	32	48	61
30A	Orange	109	93	74	55	38	48	
40A	Yellow	120	104	79	55	48.6	48	
50A	Orange	132	116	85	55	60.5	48	

Pipes should be PVC pipes compliant with JIS K 6742.

\*1) 40A, 50A adaptors for PVC pipes are the same as 1\*1/2", 2" adaptors for metal pipes.

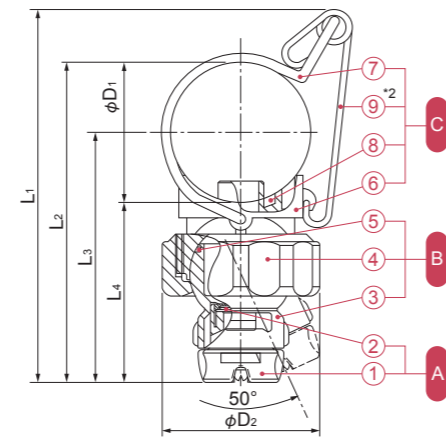

- A) Nozzle:** ① Nozzle ② Packing (FEPM)  
**B) Ball:** ③ Ball ④ Cap ⑤ O-ring (NBR)  
**C) Adaptor:** ⑥ Adaptor ⑦ Spring clip ⑧ O-ring (NBR) ⑨ Spring lock  
 \*2) ⑨ is an optional extra.

## Quick-installation Standard Flat Spray Nozzles

QB series

### Spray Performance

Spray Angle Code	Spray Capacity Code	Pipe Size		Spray Capacity (ℓ/min)				Mean Droplet Diameter (μm)	Free Passage Diameter (mm)	Color of Nozzle Body
		(inch)	(ND)	0.1 MPa	0.2 MPa	0.3 MPa	0.4 MPa			
80	80	1	25A	4.62	6.53	8.00	9.24	430	1.7	Red
	100			5.77	8.16	10.0	11.5			2.0
	120			6.93	9.80	12.0	13.9			2.3
	160			9.24	13.1	16.0	18.5			2.7
	180			10.4	14.7	18.0	20.8			2.8
	200			11.5	16.3	20.0	23.1			2.8
	240			13.9	19.6	24.0	27.7			3.2
	280			16.2	22.9	28.0	32.3			3.6
	390			22.5	31.8	39.0	45.0			4.3
65	80	1	25A	4.62	6.53	8.00	9.24	460	1.8	Red
	100			5.77	8.16	10.0	11.5			2.2
	120			6.93	9.80	12.0	13.9			2.4
	160			9.24	13.1	16.0	18.5			2.8
	180			10.4	14.7	18.0	20.8			3.0
	200			11.5	16.3	20.0	23.1			3.3
	240			13.9	19.6	24.0	27.7			3.6
	280			16.2	22.9	28.0	32.3			3.8
	390			22.5	31.8	39.0	45.0			4.5
40	80	1	25A	4.62	6.53	8.00	9.24	560	2.2	Red
	100			5.77	8.16	10.0	11.5			2.5
	120			6.93	9.80	12.0	13.9			2.8
	160			9.24	13.1	16.0	18.5			3.2
	180			10.4	14.7	18.0	20.8			3.3
	200			11.5	16.3	20.0	23.1			3.6
	240			13.9	19.6	24.0	27.7			3.9
	280			16.2	22.9	28.0	32.3			4.3
	390			22.5	31.8	39.0	45.0			5.1

### How to inquire / order

Please inquire or order for a specific nozzle using this coding system.

(Example) ISVV65280FRPP+ISB+1\*1/4QBFPP+L

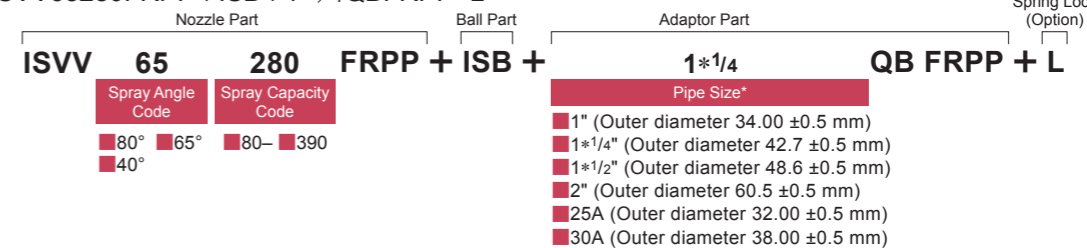

\*Note:  
 • Please refer to the dimensions of φD<sub>1</sub> (outer diameter).  
 • Order 1" adaptor for 40A, and 2" adaptor for 50A.

### CAUTIONS

- 1) Maximum operating pressure is 0.4 MPa.
- 2) Do not use under conditions where water hammer or sudden change of water pressure may occur.

## QB Related Products



### BAA+QB series

#### Features

- Air washer (air conditioning humidification) nozzle made by combining AA series nozzle (hollow cone spray nozzle) with QB series adaptor and ball parts.
- Includes a spring lock to firmly secure the nozzle in place.
- Clog-resistant structure.
- Easy installation. Just drill a hole (φ14.3 mm) into the existing piping, then insert the nozzle.

# Ejector Nozzles for Solution Agitation

EJX series

## One-direction jet type

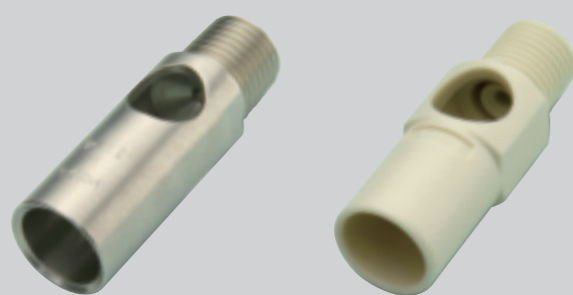

S303

PP (Polypropylene)

### Features

- Taking in surrounding liquid, EJX spouts out 3-4 times larger volume of the amount supplied.
- Compact, lightweight design with simple structure.
- Standard pressure: 0.05 MPa

### Applications

Pre-treatment Bumper painting

- Electroplating tank stirring in painting process

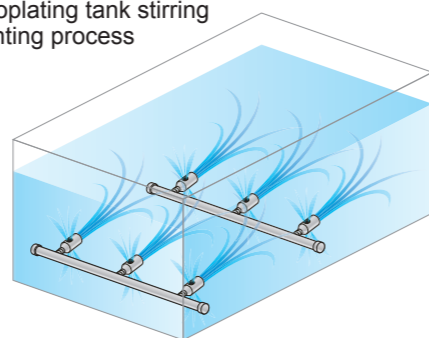

## Dimensions

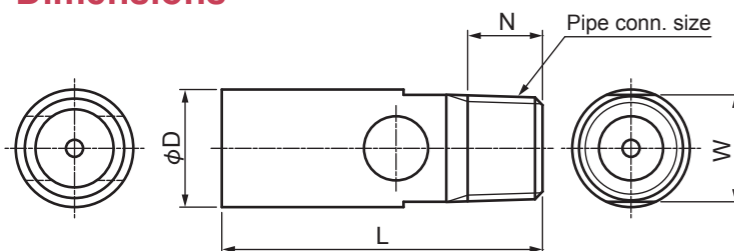

Structure: Made of metal or plastic, one-piece structure  
Material: S303 (S304 for sizes 1M and 1\*1/2 M), PP (PVC for sizes 1M and 1\*1/2 M)

Pipe Connection Size	Outer Dimensions (mm)				Mass (g)	
	L	W	φD	N	S303 S304	PP PVC
1/8 M	30	10(11) <sup>2</sup>	11	7	11	1.3 <sup>*1</sup>
1/4 M	48	14(16) <sup>2</sup>	16	10.5	26	3.2 <sup>*1</sup>
3/8 M	72	22	24	11	80	10
1/2 M	93	27	31	14	170	20
3/4 M	126	34	42	15	420	48
1M	172	60	76.3(80) <sup>2</sup>	18	2,200	460
1*1/2 M	212	80	89.1(90) <sup>2</sup>	20	3,200	540

\*1) Sizes 1/8M and 1/4M made of PP are injection molded.  
\*2) Dimensions in ( ) shows those of plastic EJX series nozzles.

## Spray Performance

Supplied Volume Code	Pipe Connection Size	Supplied Water Volume (ℓ/min)						Spray Volume (ℓ/min) [Reference value]						Free Passage Diameter (mm)
		0.03 MPa	0.05 MPa	0.1 MPa	0.15 MPa	0.2 MPa	0.3 MPa	0.03 MPa	0.05 MPa	0.1 MPa	0.15 MPa	0.2 MPa	0.3 MPa	
1	1/8 M	0.85	1.10	1.56	1.91	2.20	2.69	2.2	3.1	5.0	6.6	9.2	10	1.5
4	1/4 M	3.10	4.00	5.66	6.93	8.00	9.80	8.1	11	18	24	34	38	2.8
9	3/8 M	6.97	9.00	12.7	15.6	18.0	22.0	18	26	41	54	75	85	4.2
16	1/2 M	12.4	16.0	22.6	27.7	32.0	39.2	33	46	72	95	134	151	5.7
30	3/4 M	23.2	30.0	42.4	52.0	60.0	73.5	61	86	140	180	250	280	7.7
90	1M	69.7	90.0	127	156	180	220	180	260	410	540	760	850	13.3
160	1*1/2 M	124	160	226	277	320	392	330	460	720	950	1,340	1,510	17.5

**How to inquire / order** Please inquire or order for a specific nozzle using this coding system.

<Example> 1/4M EJX 1-4 S303

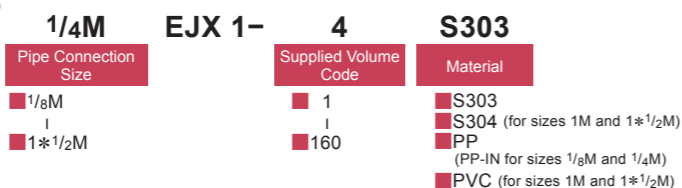

# Ejector Nozzles for Solution Agitation

EJX series

## High flow rate type



### Features

- High flow rate EJX series, featuring 1.5-2 times higher spray impact (flow velocity) compared to the conventional EJX series, effectively agitates liquids for cleaning and promoting reactions.
- Standard pressure: 0.1 MPa

### Applications

Pre-treatment Bumper painting

- Electroplating tank stirring in painting process

## Dimensions

1/4M EJX 1\*0/5.8PP-IN (φ19-50, φ6)

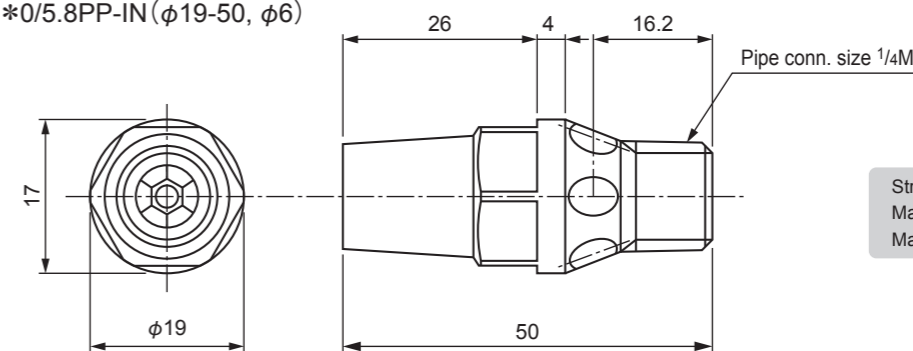

Structure: One-piece structure  
Material: PP (injection-molded)  
Mass: 5 g

1/2M EJX 1\*0/22PP (φ32-110)

3/4M EJX 1\*0/64PP (φ45-160)

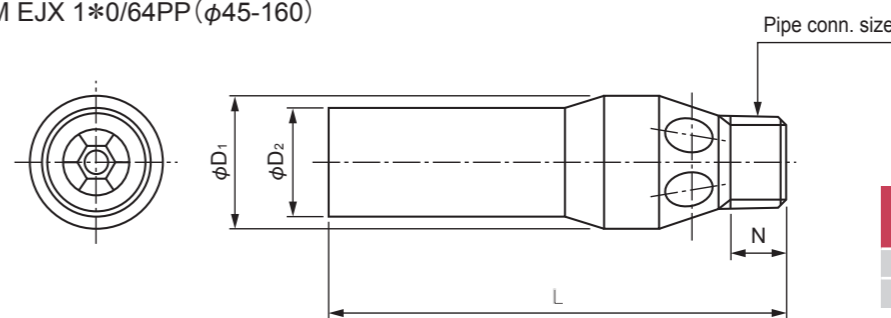

Structure: One-piece structure  
Material: PP

Pipe Conn. Size	Outer Dimensions (mm)				Mass (g)
	L	φD <sub>1</sub>	φD <sub>2</sub>	N	
1/2M	110	32	25	14	30
3/4M	160	45	41	15	90

Configurations differ depending on nozzle codes.

## Spray Performance

Nozzle Code	Supplied Water Volume (ℓ/min)						Spray Volume (ℓ/min) [Reference value]						Free Passage Diameter (mm)
	0.03 MPa	0.05 MPa	0.1 MPa	0.15 MPa	0.2 MPa	0.3 MPa	0.03 MPa	0.05 MPa	0.1 MPa	0.15 MPa	0.2 MPa	0.3 MPa	
1/4M EJX 1*0/5.8PP-IN (φ19-50, φ6)	3.20	4.00	5.80	7.10	8.20	10.0	10.5	13.4	18.8	23.2	27.0	34.5	2.8
1/2M EJX 1*0/22PP (φ32-110)	12.0	16.0	22.0	27.5	32.0	39.0	36.0	47.0	73.0	95.0	111	134	5.5
3/4M EJX 1*0/64PP (φ45-160)	36.0	46.0	64.0	77.0	90.6	109	103	140	206	260	301	380	9.1

**How to inquire / order**

Please inquire or order for a specific nozzle with the nozzle code shown in the above chart.

# Air Booster Nozzles

Patented

TAIFUJet® series

## TAIFUJet® Compressor Air Nozzles

### Features

- The special configuration of TAIFUJet takes in surrounding air and boosts powerful air flow.
- Produces powerful and uniform air flow whilst saves on air consumption.

### Applications

- Casting
- Machining
- Assembly
- Pressing
- Pre-treatment
- Middle coat
- Top coat
- Bumper painting
- Off line

- Blow-off drying, dust removal in all the above processes
- Blowing off paint dust, debris on carriage in paint/coating process
- Blow-off drying in engine block

### Low noise level (Quiet operation)

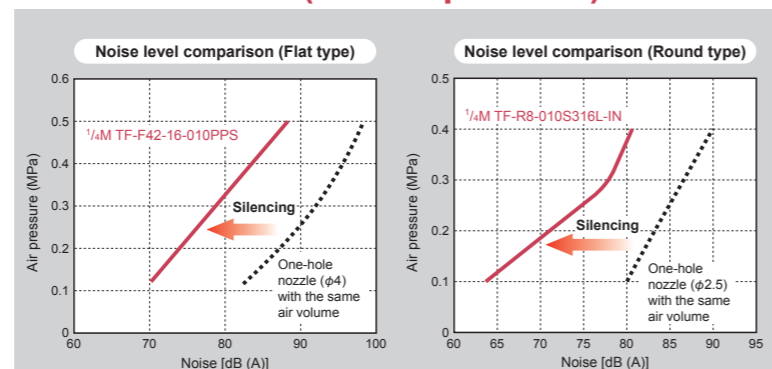

● Measured point: 1 m in front of nozzle, at 1 m height ● Background noise: 58 dB (A)

TAIFUJet reduces noise level by 10 dB or more compared to a one-hole nozzle with the same air volume, resulting in better working environments.

### TAIFUJet® Flat Type for compressors

- Plastic 42 mm wide type

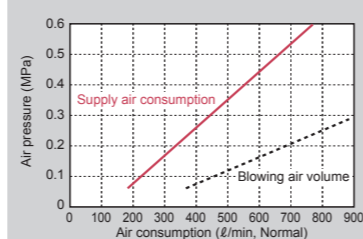
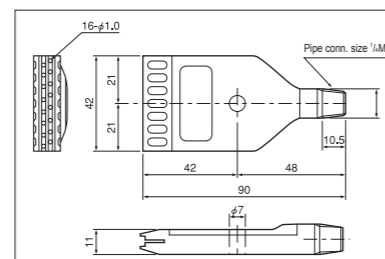

#### Flat Type

Material: PPS  
Mass: 30 g  
Max. air pressure: 0.7 MPa (100 psi)  
Max. allowable temperature: 130°C (260°F)

[Spray pattern]

- Plastic 121 mm wide Broad type

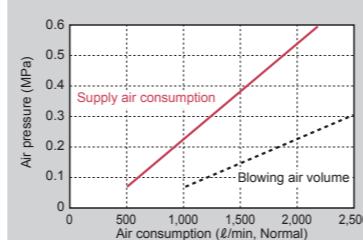
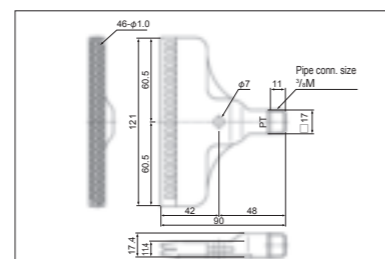

#### Flat Type

Material: PPS  
Mass: 62 g  
Max. air pressure: 0.7 MPa (100 psi)  
Max. allowable temperature: 120°C (240°F)

[Spray pattern]

**How to inquire / order** Please inquire or order for a specific nozzle using these product codes.

**42 mm wide type** 1/4M(PT) TF-F 42-16-010 PPS  
 Thread Type: (PT) (NPT)  
**121 mm wide Broad type** 3/8M TF-F 121-46-010 PPS

### Air Booster Nozzles

TAIFUJet® series

- Plastic 24 mm wide Compact type



#### Flat Type

[Spray pattern]

Material: PPS  
Mass: 4 g  
Max. air pressure: 0.7 MPa (100 psi)  
Max. allowable temperature: 120°C (240°F)

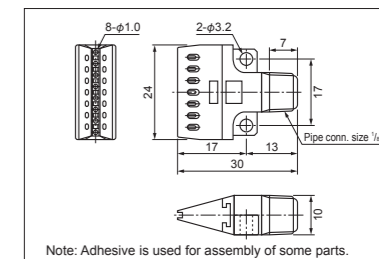

Note: Adhesive is used for assembly of some parts.

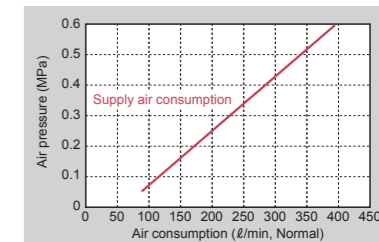

**How to inquire / order** Please inquire or order using this product code.

**24 mm wide Compact type** 1/8M TF-F 24-8-010 PPS-IN

- Stainless steel 42 mm wide type



#### Flat Type

[Spray pattern]

Material: S316L equivalent  
Mass: 144 g  
Max. air pressure: 1.0 MPa (140 psi)  
Max. allowable temperature: 400°C (750°F)  
1/4MTF-F42-16 is available in orifice diameters of φ0.8, φ1.0, or φ1.2 mm.

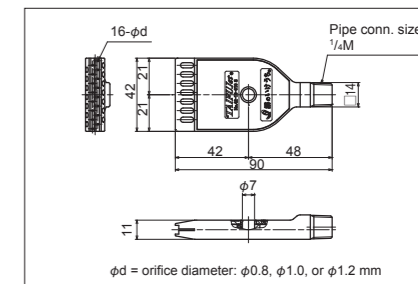

φd = orifice diameter: φ0.8, φ1.0, or φ1.2 mm

#### [Orifice diameter φ0.8]

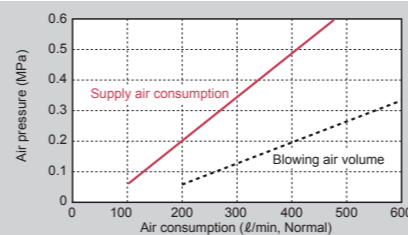

#### [Orifice diameter φ1.0]

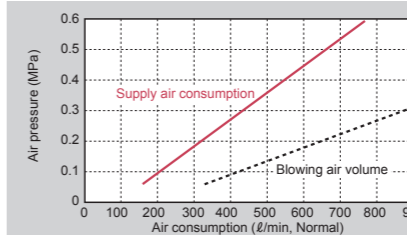

#### [Orifice diameter φ1.2]

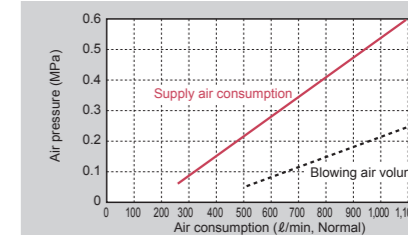

- Stainless steel 50 mm wide type



#### Flat Type

[Spray pattern]

Material: S304  
Mass: 140 g  
Max. air pressure: 1.0 MPa (140 psi)  
Max. allowable temperature: 400°C (750°F)

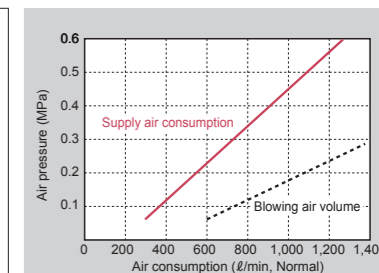
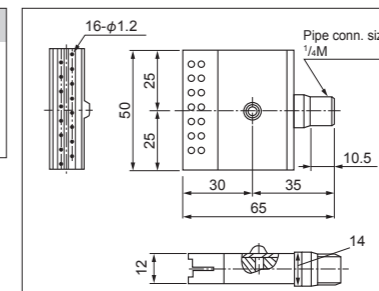

**How to inquire / order** Please inquire or order for a specific nozzle using this coding system.

**42 mm wide type** (Example) 1/4M (PT) TF-F 42-16-010 S316L-IN  
 Thread Type: (PT) (NPT) Orifice Diameter Code: 008 (φ0.8), 010 (φ1.0), 012 (φ1.2)  
**50 mm wide type** 1/4M TF-F 50-16-012 S304

TAIFUJet® Round Type for compressors

● Plastic

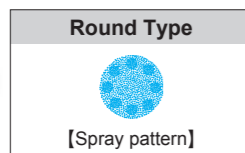

Material: PP  
 Mass: 2 g  
 Max. air pressure: 0.7 MPa (100 psi)  
 Max. allowable temperature: 60°C (140°F)

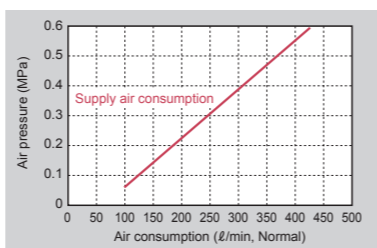
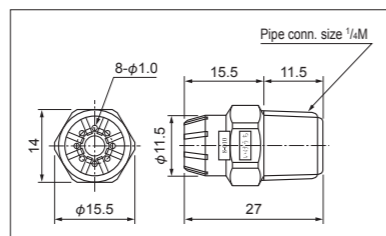

● Stainless steel

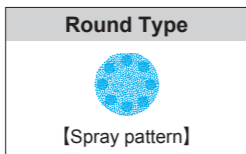

Material: S316L equivalent  
 Max. air pressure: 1.0 MPa (140 psi)  
 Max. allowable temperature: 400°C (750°F)

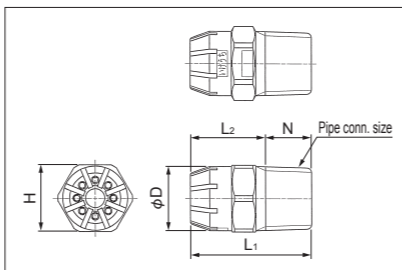

■ Specifications

Orifice Diameter Code	Pipe Connection Size		Orifice Diameter (mm)	Air Consumption (ℓ/min, Normal)		
	1/8M	1/4M		0.1 MPa	0.3 MPa	0.5 MPa
8-008	○	—	0.8	80	155	235
8-010	○	○	1.0	125	245	365
8-012	○	○	1.2	180	360	540
8-014	○	○	1.4	240	480	720
8-016	—	○	1.6	320	630	940

■ Dimensions

Pipe Connection Size	Dimensions (mm)					Mass (g)
	L1	L2	H	φD	N	
1/8M	20	13	12	12	7	7
1/4M	25	15.5	14	13.5	9.5	12

Note: Surface gloss may differ depending on nozzle thread size.

**How to inquire / order** Please inquire or order for a specific nozzle using this coding system.

Plastic

1/4M TF-R 8-010 PP-IN

Stainless steel

Example) 1/8M TF-R 8-010 S316L-IN

1/8M TF-R 8-010 S316L-IN

Pipe Connection Size  
 ■ 1/8M  
 ■ 1/4M

Orifice Diameter Code  
 ■ 8-008 ■ 8-014  
 ■ 8-010 ■ 8-016  
 ■ 8-012

TAIFUJet® Long Flat Type for compressors



● Available in 13 spray width types from 100 mm to 1400 mm, for blowing air over greater widths.

Material: S304

TAIFUJet® Cluster Header Type for compressors

● Cluster header type

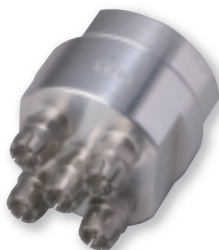

● 3-Cluster header type



Features

- Header with a cluster of multiple round-type stainless steel air nozzles.
- One cluster can be equipped with 4, 5, or 7 nozzles upon request.

Material: S303

TAIFUJet® Blower Air Nozzles

Features

- Blower air nozzles, reducing energy cost to about 1/3 that of compressed air-driven nozzles.
- Unique design combining air-amplification, even air flow distribution, and low-noise operation.

Applications

Casting Machining Assembly Pressing Pre-treatment Middle coat Top coat Bumper painting Off line

- Blow-off drying, dust removal in all the above processes
- Blowing off paint dust, debris on carriage in paint/coating process
- Blow-off drying in engine block

TAIFUJet® Flat Type for blowers Air nozzle with a 42 mm wide even jet

● Plastic



Material: ABS  
 Mass: 26 g  
 Max. air pressure: 100 kPa (14 psi)  
 Max. allowable temperature: 80°C (170°F)

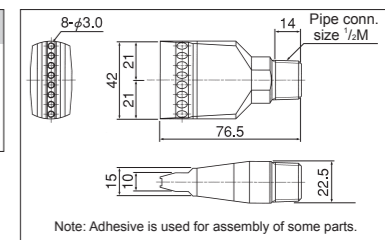
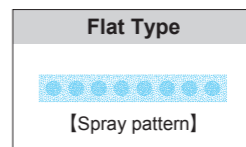

Note: Adhesive is used for assembly of some parts.

● Metal



Material: Aluminum A5052  
 Mass: 65 g  
 Max. air pressure: 100 kPa (14 psi)  
 Max. allowable temperature: 316°C (600°F)

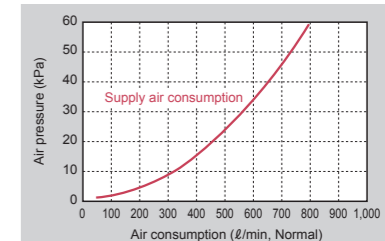

**How to inquire / order** Please inquire or order using this product code (select material).

Example) 1/2M TF-BF 42-8-030 ABS

1/2M TF-BF 42-8-030 ABS

Material  
 ■ ABS ■ A5052

TAIFUJet® Round Type for blowers Air nozzle with pinpoint aim for gaps and narrow spaces

● Plastic



Material: ABS  
 Mass: 8 g  
 Max. air pressure: 100 kPa (14 psi)  
 Max. allowable temperature: 80°C (170°F)

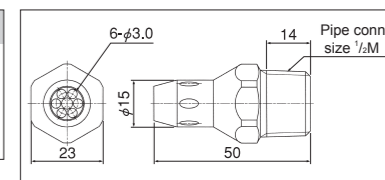
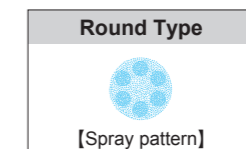

● Metal



Material: Aluminum A5052  
 Mass: 20 g  
 Max. air pressure: 100 kPa (14 psi)  
 Max. allowable temperature: 400°C (750°F)

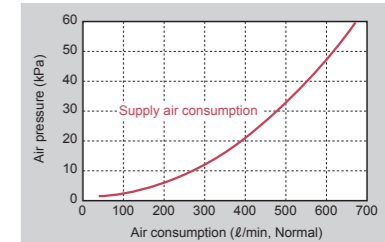

**How to inquire / order** Please inquire or order using this product code (select material).

Example) 1/2M TF-BR 6-030 ABS

1/2M TF-BR 6-030 ABS

Material  
 ■ ABS ■ A5052

TAIFUJet® Long Flat Type for blowers

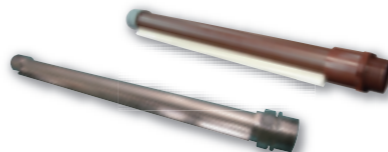

- Air blowing over greater widths

Material: Plastic resin (PPS nozzle tip and HTPVC pipe header) or Aluminum A5052

# Air Nozzles Solid Stream Type

CCP-A series

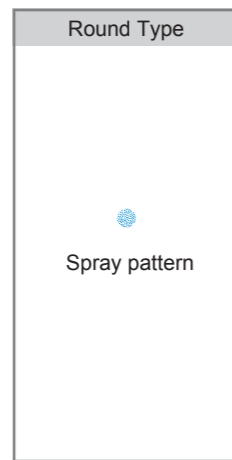
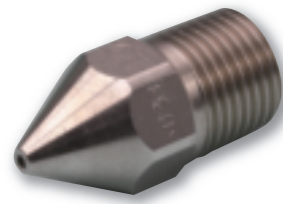

### Features

- Compressor air nozzle.
- Spraying air in a solid stream through a single orifice yields strong propagation for highly effective air blowing.
- Product lineup orifice diameters range from  $\phi 1.0$  to  $\phi 2.5$ .
- Delivering good performance for low cost, ideal for use in large quantities.

### Applications

Casting Forging Machining Pressing

- Blow-off drying in casting process
- Drying/ Blow-off drying in machining process

## Dimensions

Material: S303

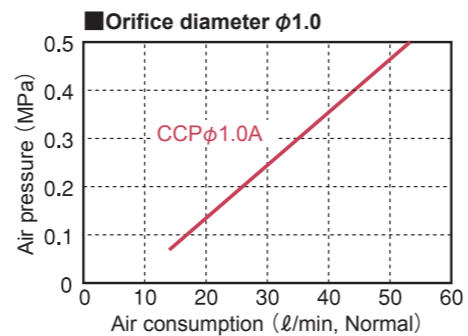
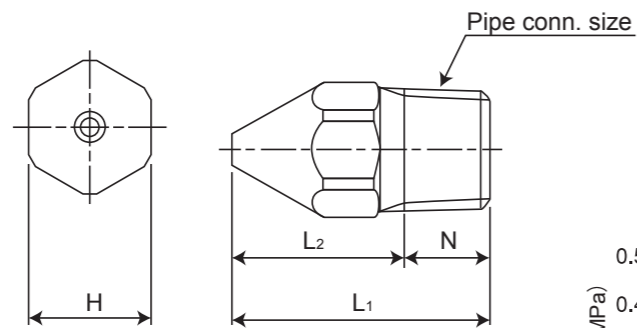

Pipe Conn. Size	Dimensions (mm)				Mass (g)
	L <sub>1</sub>	L <sub>2</sub>	H	N	
1/8M	21	14	10	7	7.2
1/4M	30	19.5	14	10.5	19

## Spray Performance

Orifice Diameter Code	Pipe Conn. Size	Air Consumption (ℓ/min, Normal)					Orifice Diameter (mm)
		Air Consumption (ℓ/min, Normal)					
		0.1 MPa	0.2 MPa	0.3 MPa	0.4 MPa	0.5 MPa	
$\phi 1.0A$	1/8M	17	26	35	44	53	1.0
$\phi 1.5A$		40	60	80	100	120	1.5
$\phi 2.0A$	1/4M	70	104	135	172	206	2.0
$\phi 2.5A$		109	162	215	268	321	2.5

**How to inquire / order** Please inquire or order for a specific nozzle using this coding system.

<Example> 1/8M CCP  $\phi 1.0A$  S303

**1/8M** Pipe Connection Size  
 ■ 1/8M  
 ■ 1/4M  
**CCP**  
 **$\phi 1.0A$**  Orifice Diameter Code  
 ■  $\phi 1.0A$   
 ■  $\phi 1.5A$   
 ■  $\phi 2.0A$   
 ■  $\phi 2.5A$   
**S303**

# Air Nozzles Multi-orifice Flat Spray Type

HF series

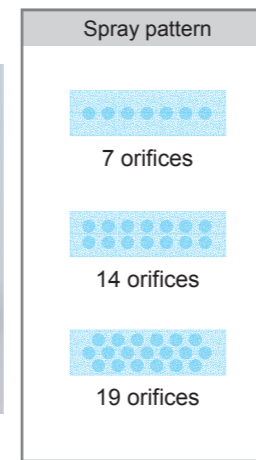

### Features

- Compressor air nozzle.
- Produces uniform air blow from multi orifices.
- Noise level reduced by more than 10 dB(A) compared to a one-hole air nozzle.
- Compact design, 47 mm in length (47.5 mm for 3/8M).
- Detachable into three parts, easy to clean the nozzle orifices.
- Made of stainless steel with high resistance to corrosion and heat.

### Applications

Casting Machining

- Blow-off drying in casting process
- Drying/ Blow-off drying in machining process

## Dimensions

① Spray tip ② Cap ③ Adaptor  
 Material: S303  
 Optional material: S316

Pipe Conn. Size	Dimensions (mm)				Mass (g)
	L	H	W	N	
1/4M	47	23	14	10.5	70
3/8M	47.5	23	14	11	75

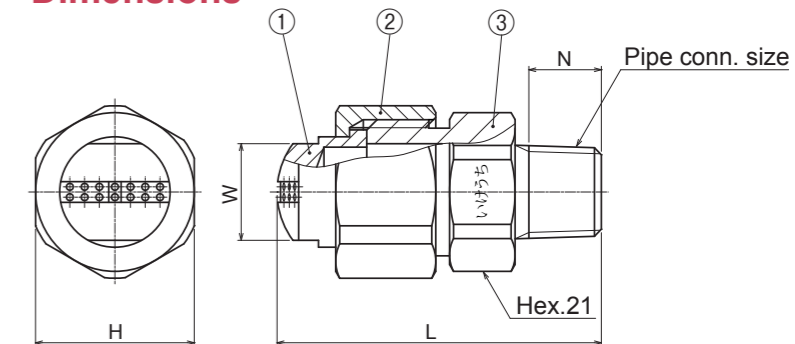

## Spray Performance

7-012 Air spray width and thickness (mm)							14-010 Air spray width and thickness (mm)							19-010 Air spray width and thickness (mm)									
Pressure	Spray Distance	0.1 MPa		0.3 MPa		0.4 MPa		Pressure	Spray Distance	0.1 MPa		0.3 MPa		0.4 MPa		Pressure	Spray Distance	0.1 MPa		0.3 MPa		0.4 MPa	
		Width	Thickness	Width	Thickness	Width	Thickness			Width	Thickness	Width	Thickness	Width	Thickness			Width	Thickness	Width	Thickness	Width	Thickness
50 mm	60	40	60	60	60	60	50 mm	60	40	70	60	80	60	50 mm	60	40	80	60	80	60	60	60	
150 mm	110	80	120	120	120	120	150 mm	120	80	140	120	150	120	150 mm	120	80	140	120	150	120	120	120	
300 mm	150	120	190	150	200	160	300 mm	170	120	200	150	220	160	300 mm	180	120	210	150	230	160	160	160	

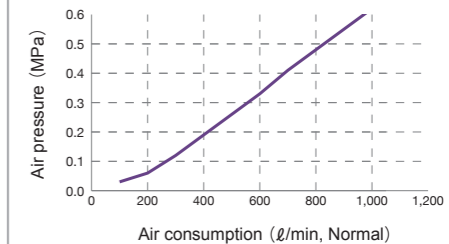
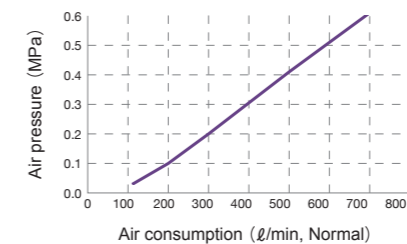
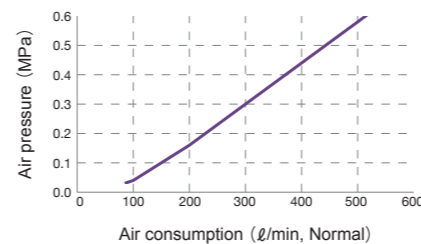

**How to inquire / order** Please inquire or order for a specific nozzle using this coding system.

<Example> 1/4M HF 7-012 S303

**1/4M** Pipe Connection Size  
 ■ 1/4M  
 ■ 3/8M  
**HF**  
**7-012** Nozzle Code  
 ■ 7-012  
 ■ 14-010  
 ■ 19-010  
**S303**



# Air Nozzles Slit Type

SLNHA-H series / SLNB series

## SLNHA-H series Slit Nozzles for compressors

Patented

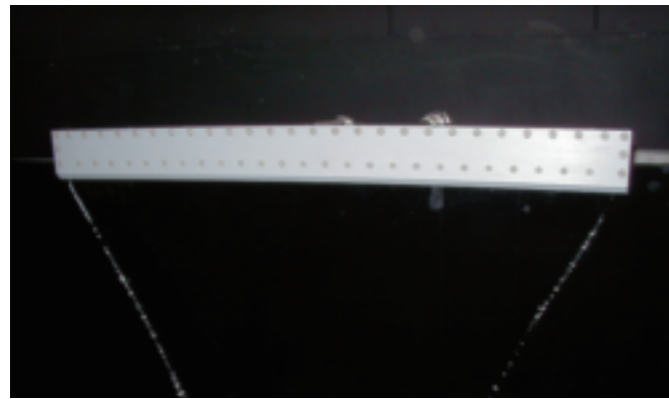

### Features

- Even spray impact force distribution with less than 20% variation.
- Compact design. Unit is only 20–24 mm thick! (PVC-made is 34 mm) Can be installed in narrow spaces between support rolls.

### Applications

- Casting Forging Machining Painting/Coating Bumper painting Off line
- For blow-off drying, debris clearing, drying in all of these processes

Note: SLNHA-H series is an air nozzle. Water is sprayed here to better show the spray pattern.

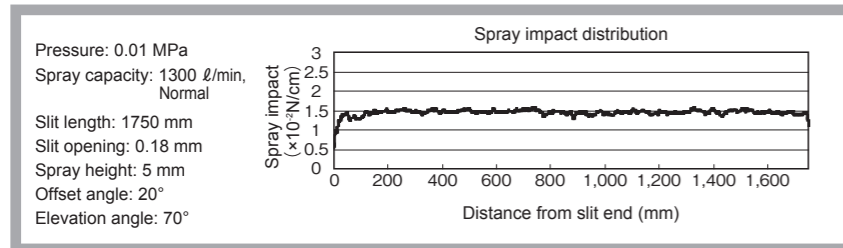
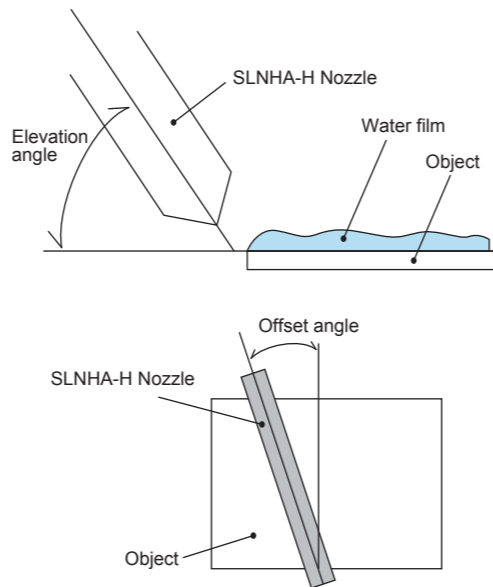

For details please ask for our hydraulic spray nozzle catalog.

## SLNB series Slit Nozzles for blowers

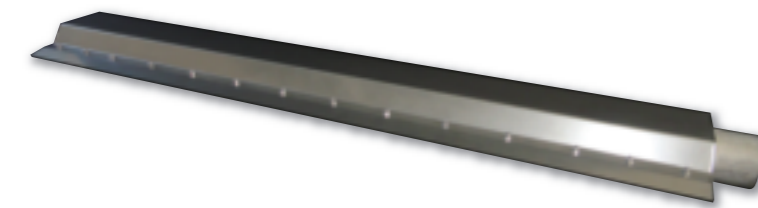

### Features

- **Minimal pressure loss, Tapered nose type**  
Pressure loss is minimal to enable high spray impact performance. Long thin slit with tapered nose is suitable for installation in a narrow space, such as between support rolls. Air blowing close to the target is possible.
- **Energy saving**  
Drastic energy saving is achieved by switching from compressor-using type.

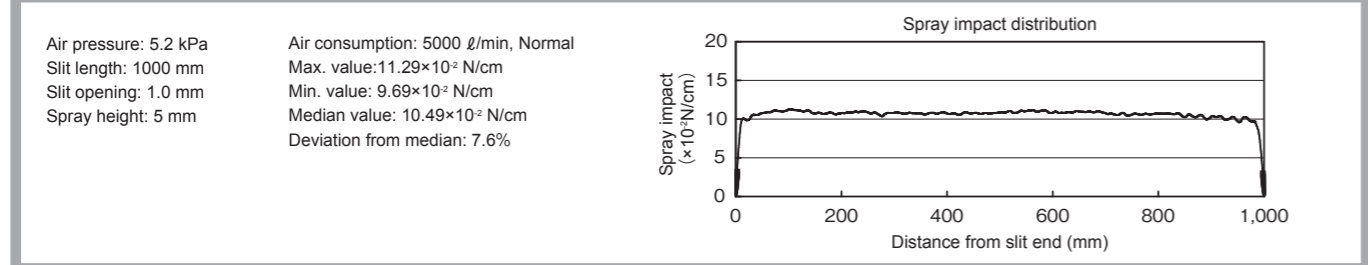

For details please ask for our hydraulic spray nozzle catalog.

# Auto Reverse Self-cleaning Filter

Patented  
ARS Filter series

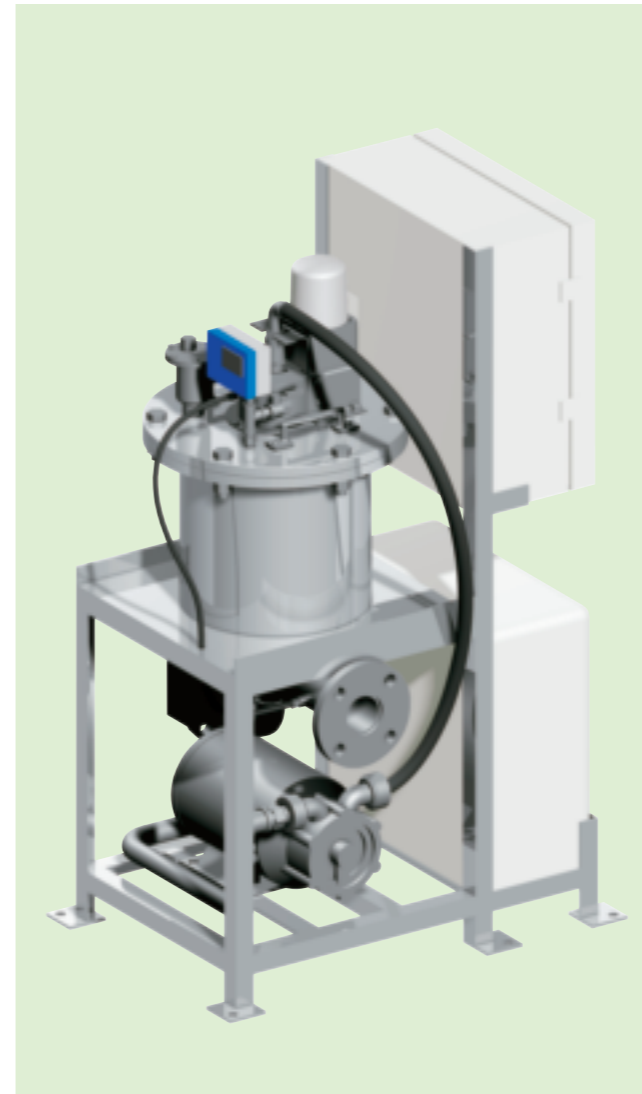

### Features

- ARS Filter employs a high-pressure jet spray backwashing method. It ensures stable cleaning, without requiring consumable parts such as cleaning brushes.
- Compact design to install in a small space.
- Detecting the pressure difference caused by an accumulation of foreign particles on the filter, ARS starts jet spray cleaning automatically and discharges foreign particles through the drain.

### Material

- Main body: Stainless steel (except for cleaning water pump and hose, which may not be stainless steel in some parts of wetted surface)
- Packing and O-ring: FKM

### Applications

Machining Pre-treatment Sealing Top coat

- Filtration of circulated water and cleaning water
- Recycling of water for air washer

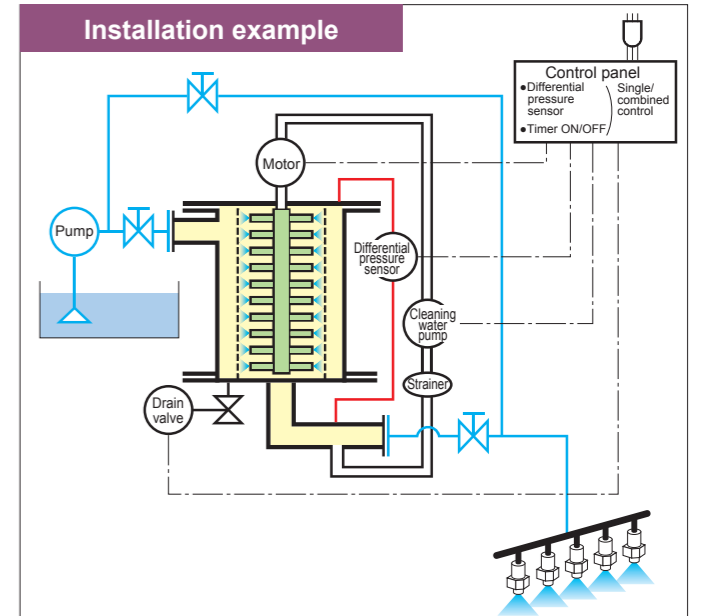

## Specifications

Model Number		ARS-150	ARS-500	ARS-1000	ARS-2500
Maximum Filtration Capacity (ℓ/min)		150	500	1000	2500
Maximum Allowable Pressure (MPa)		1.0	1.0 <sup>2</sup>	1.0	1.0
Power Requirements		100 VAC x 0.3 kW (Steel pump) 100 VAC x 0.5 kW (Stainless steel pump) <sup>1</sup>	200 VAC (3-phase) x 1.7 kW	200 VAC (3-phase) x 2.5 kW	200 VAC (3-phase) x 3.8 kW
Pipe Connection Size (A)	Inlet	32	50	80	150
	Outlet				
	Drain	25	25	40	50
Filter Screen Mesh Size	Metal Wire Screen <sup>3</sup>	#300 #150 #100 #60 #35	#150 #100 #60 #35	#150 #100 #60 #35	#150 #100 #60 #35
	Wedge Wire Screen (μm)	–	100 150 300 500	100 150 300 500	100 150 300 500

<sup>1</sup>1) Stainless steel cleaning pump is optional.

<sup>2</sup>2) 0.3 MPa for clamp lid type. (1.0 MPa for flange lid type only)

<sup>3</sup>3) Filter screen mesh size are shown in parenthesis: #300 (45 μm), #150 (109 μm), #100 (145 μm), #60 (240 μm), #35 (520 μm).

## Dimensions and Mass

Model Number	ARS-150	ARS-500	ARS-1000	ARS-2500
Dimensions (WxDxH) <sup>4</sup> (mm)	360x510x1,300	433x666x1,053	560x1,000x1,223	1,000x1,800x1,882
Mass (kg)	67 (Steel pump)	115	175	850
	71 (Stainless steel pump) <sup>1</sup>			

<sup>1</sup>1) Stainless steel cleaning pump is optional.

<sup>4</sup>4) Width x Depth x Height

# Inquiry Form for Cooling System/Cooling Unit

For cooling system/unit inquiries, please fill out the form below and e-mail it to us ([overseas@kirinoikeuchi.co.jp](mailto:overseas@kirinoikeuchi.co.jp)) so that we can offer the cooling system/unit most suitable for your needs.

Subject	Contents	
Your company information	Company Name	
	Contact person	
	Department	
	Tel/Fax	Tel) _____ Fax) _____
	E-mail	
	Address	
	Country	
	Power supply	Voltage ( _____ VAC), Frequency ( _____ Hz)
Equipment	1)Equipment name	3)Size of space to be cooled [Dim. _____ x _____ x _____ mm]
	2)Equipment capacity	4)Ventilation rate [Exhaust air volume: _____ m <sup>3</sup> /min]
Cooling specifications	1)Purpose(s) of cooling <input type="checkbox"/> Quality improvement <input type="checkbox"/> Productivity improvement <input type="checkbox"/> Cost reduction <input type="checkbox"/> Energy saving <input type="checkbox"/> Water saving <input type="checkbox"/> Others( _____ )	
	2)Cooling mode/period <input type="checkbox"/> On production line <input type="checkbox"/> Batch processing <input type="checkbox"/> Others( _____ )	
	3)Cooling method <input type="checkbox"/> Air cooling <input type="checkbox"/> Fog spray cooling ( <input type="checkbox"/> Ultra-fine fog <input type="checkbox"/> Fine-fog <input type="checkbox"/> Semi-fine fog <input type="checkbox"/> Coarse fog) <input type="checkbox"/> Immersion cooling <input type="checkbox"/> Water curtain cooling <input type="checkbox"/> Others( _____ )	
	4)Control method(s) <input type="checkbox"/> Manual control (by <input type="checkbox"/> pressure <input type="checkbox"/> flow-rate) <input type="checkbox"/> Automatic control (by <input type="checkbox"/> pressure <input type="checkbox"/> flow-rate <input type="checkbox"/> time <input type="checkbox"/> temperature) <input type="checkbox"/> Others( _____ )	
	5)Cooling target object: Name/material ( _____ )	11)Cooling distance _____ m
	6)Cooling target surface: Name/material ( _____ )	12)Volume _____ mm <sup>3</sup>
	7)Temperature before cooling _____ °C	13)Surface area _____ mm <sup>2</sup>
	8)Temperature after cooling _____ °C	14)Specific heat _____ kcal/kg°C
	9)Cooling time _____ sec	15)Specific gravity _____ g/cm <sup>3</sup>
	10)Line speed _____ m/min	16)Heat conductivity _____ kcal/mh°C
Request/ purpose for cooling	Current problems:	Your requests/requirements:
Sketch/drawing of equipment/process:		
Remarks:		